



## ▶ PSSuniversal

**PILZ**  
THE SPIRIT OF SAFETY

Installation Manual-21262-EN-09  
- Programmable control systems PSS



This document is the original document.

Where unavoidable, for reasons of readability, the masculine form has been selected when formulating this document. We do assure you that all persons are regarded without discrimination and on an equal basis.

All rights to this documentation are reserved by Pilz GmbH & Co. KG. Copies may be made for the user's internal purposes. Suggestions and comments for improving this documentation will be gratefully received.

Pilz®, PIT®, PMI®, PNOZ®, Primo®, PSEN®, PSS®, PVIS®, SafetyBUS p®, SafetyEYE®, SafetyNET p®, the spirit of safety® are registered and protected trademarks of Pilz GmbH & Co. KG in some countries.



SD means Secure Digital

<b>1</b>	<b>Introduction</b> .....	<b>5</b>
1.1	Validity of documentation .....	5
1.2	Definition of symbols .....	5
<b>2</b>	<b>Safety</b> .....	<b>7</b>
2.1	General safety guidelines .....	7
2.2	Use of qualified personnel .....	7
2.3	Safety during installation .....	7
2.3.1	Supply voltage .....	7
2.3.2	Installation .....	8
2.3.3	ESD .....	9
2.4	Application conditions in accordance with EN 45545-2 (fire protection on railway vehicles) ...	10
<b>3</b>	<b>Electromagnetic Compatibility (EMC)</b> .....	<b>11</b>
3.1	Overview .....	11
3.2	Making the installation EMC-compliant .....	12
3.2.1	Connecting the earth cables .....	12
3.2.2	Cabling .....	12
3.2.3	Connecting the fieldbuses .....	13
3.2.4	Equipotential bonding .....	13
3.2.5	Screening .....	13
3.2.6	Suppression on inductive loads .....	14
3.2.7	Installing within an enclosure or wall-mounting .....	14
3.2.8	Lighting in the control cabinet .....	15
3.3	Testing the EMC-compliance of an installation .....	15
<b>4</b>	<b>Installing the PSSu system</b> .....	<b>17</b>
4.1	Modular structure .....	17
4.2	Module layout .....	19
4.3	Connection levels .....	20
4.3.1	Connections on the base modules .....	20
4.3.1.1	Colour marking on the connection levels .....	21
4.3.2	Connections on the compact modules .....	21
4.4	Installation environment .....	23
4.4.1	Mounting distances .....	24
4.5	Mechanical coding of the electronic modules .....	26
4.5.1	Removing the mechanical coding from an electronic module .....	27
4.5.2	Removing the mechanical coding from a base module .....	27
4.6	Steps .....	29
4.6.1	Procedure for installing the PSSuniversal .....	29
4.6.2	Procedure for removing the PSSuniversal .....	30
<b>5</b>	<b>Installing the modules</b> .....	<b>32</b>
5.1	Head modules .....	32
5.1.1	Installing the head module .....	32
5.1.2	Removing the head module .....	33
5.2	Base modules .....	34
5.2.1	Installing base modules .....	34

5.2.2	Removing base modules.....	35
5.3	Electronic modules.....	36
5.3.1	Inserting an electronic module.....	37
5.3.2	Removing an electronic module.....	38
5.4	Compact modules.....	38
5.4.1	Install the compact modules.....	38
5.4.2	Remove the compact modules.....	40
5.5	End bracket.....	41
5.5.1	Install an end bracket on the left.....	41
5.5.2	Install a connection plate on the right.....	42
5.5.3	Remove the end bracket on the left.....	43
5.5.4	Remove the connection plate on the right.....	44
<b>6</b>	<b>Connecting the PSSu system .....</b>	<b>45</b>
6.1	Supply voltages.....	45
6.2	Power supplies.....	47
6.3	Earthing.....	52
6.4	Separation of supply.....	52
6.5	Wiring the base modules.....	54
6.5.1	Cable requirements.....	55
6.5.2	Connecting FS inputs and outputs.....	56
6.6	Wiring the compact modules.....	56
6.6.1	Cable requirements.....	57
6.7	Wiring test and function test.....	58

# 1 Introduction

## 1.1 Validity of documentation

This installation manual contains all the information you need to install a PSSu system. A description of its functionality plus operational guidelines can be found in the following documents:

- ▶ System Description PSS 4000
- ▶ PSSuniversal System Description

The modules for the PSSuniversal are described in detail in the respective operating manuals.

This documentation is intended for instruction and should be retained for future reference.

This documentation is valid for the PSSuniversal.

It is valid until new documentation is published. The latest documentation is always enclosed with the unit.

## 1.2 Definition of symbols

Information that is particularly important is identified as follows:



### **DANGER!**

This warning must be heeded! It warns of a hazardous situation that poses an immediate threat of serious injury and death and indicates preventive measures that can be taken.



### **WARNING!**

This warning must be heeded! It warns of a hazardous situation that could lead to serious injury and death and indicates preventive measures that can be taken.



### **CAUTION!**

This refers to a hazard that can lead to a less serious or minor injury plus material damage, and also provides information on preventive measures that can be taken.



### **NOTICE**

This describes a situation in which the product or devices could be damaged and also provides information on preventive measures that can be taken. It also highlights areas within the text that are of particular importance.



**INFORMATION**

This gives advice on applications and provides information on special features.

## 2 Safety

### 2.1 General safety guidelines

Please note the following general safety guidelines:

- ▶ Ensure VDE and local regulations are met, especially those relating to safety. The relevant safety regulations for the respective application must also be met.
- ▶ The PSSuniversal is exclusively designed for use in an industrial environment. It is not suitable for use in a domestic environment, as this can lead to interference.
- ▶ The deciding factors in how to use the device are the requirements of the relevant certification body (e.g. BG or TÜV).
- ▶ In particular please observe the wiring regulations.
- ▶ If the modules are altered in any way, such as exchanging a component or carrying out soldering work, the guarantee, and any approval, will be rendered invalid.
- ▶ The date of manufacture can be found on the quality seal.
- ▶ Modules must be disposed of properly when they reach the end of their service life.

### 2.2 Use of qualified personnel

The products may only be assembled, installed, programmed, commissioned, operated, maintained and decommissioned by persons who are competent to do so.

A competent person is a qualified and knowledgeable person who, because of their training, experience and current professional activity, has the specialist knowledge required. In order to inspect, assess and handle products, devices, systems, plant and machinery, this person must be familiar with the state of the art and the applicable national, European and international laws, directives and standards.

It is the company's responsibility only to employ personnel who

- ▶ Are familiar with the basic regulations concerning health and safety / accident prevention,
- ▶ Have read and understood the information provided in the section entitled Safety
- ▶ Have a good knowledge of the generic and specialist standards applicable to the specific application.

### 2.3 Safety during installation

#### 2.3.1 Supply voltage

Please refer to the technical details of the head modules with integrated supply voltage or of the supply voltage modules.

The PSSuniversal requires a 24 VDC supply. Check that the external power supply provides this voltage.

The tolerance of the supply voltage must correspond to the technical details of the supply voltage modules. The correct operation of the PSSuniversal cannot be guaranteed outside this range.

Overvoltage and interference spikes can damage the PSSuniversal. You should therefore ensure that appropriate EMC measures are taken.

To achieve the lowest possible residual ripple ( $< \pm 1.2 \text{ V}$ ), we recommend that you install a three-phase bridge rectifier or regulated supply.

Protect the external power supply by fitting a fuse between the external power supply and the control system. The size of the fuse will depend on the specification of the external power supply, the conductor cross section and on local regulations.



**WARNING!**

Risk of electrocution!

Safe electrical isolation must be ensured for the external power supply that generates the supply voltage. Power supplies must meet the requirements of the standards, such as EN 62368-1 or EN 61010-2-201, for example.

Connect together the 0V connections on all the 24 V power supplies and earth the 0 V mains at a single point, or ensure that measures are in place to monitor for earth faults.

The connection of the 0 V supply to the central earth bar or earth fault monitor must be in accordance with national regulations (such as EN 60204-1, NFPA 79:17-7, NEC: Article 250).



**WARNING!**

Risk of electrocution!

If voltages higher than 50 VAC or 120 VDC are connected to the PSSuniversal, e.g. to switch contacts on relay modules, please note the following:

- Specific accident prevention regulations apply.
- For safety reasons, only the protective earth (PE) may be connected to the C-rail of the supply group.

### 2.3.2 Installation

Please note:

- ▶ Install the PSSuniversal in a protected environment, e.g. in a control cabinet or a protected interior compartment.
- ▶ Comply with the protection class required for the installation environment.
- ▶ Refer to the technical details of the relevant modules during installation.
- ▶ Ensure there is sufficient ventilation to prevent heat building up. Monitor the ambient temperature to ensure it complies with the values stated in the modules' technical data.



**CAUTION!**

Risk of burns!

If a PSSu system is operated at an ambient temperature of more than 45 °C, surface temperatures on the housing may reach more than 90 °C at full load.

Do not touch the housing!

- ▶ In extreme ambient conditions, additional measures such as air conditioning may be required in order to keep within the prescribed value range.
- ▶ Sufficient protection must be provided to prevent the built-in controller from being touched unintentionally.
- ▶ Further information on installation can be found in the chapter entitled [Installing the PSSu system](#) [ 17].

### 2.3.3

#### ESD



**NOTICE**

**Damage due to electrostatic discharge!**

Electrostatic discharge can damage components. Ensure against discharge before touching the product, e.g. by touching an earthed, conductive surface or by wearing an earthed armband.

## 2.4 Application conditions in accordance with EN 45545-2 (fire protection on railway vehicles)

All operation and design categories up to hazard level HL3 can be implemented using the -R electronic modules and -T base modules.

Please note that when many modules are connected in a row, grouping rules 1 and 2 from EN 45545-2 must be applied. The total weight of the relevant material fraction of a PSSu system, i.e. of a connected control unit, may be a max. 500 g (HL2) or max. 100 g (HL3) in total. In the PSSu system, only the base modules have a relevant material fraction.

The relevant material fraction of the modules can be found in the table below:

Base module product name	Order number	Relevant material fraction	
		HL2	HL3
PSSu BS-R 2/8 C-T	314655	12 g of 500 g	12 g of 100 g
PSSu BS-R 2/8 S-T	314654	12 g of 500g	12 g of 100 g
PSSu BS 1/8 C-T	314651	7 g of 500 g	7 g of 100 g
PSSu BS 1/8 S-T	314650	7 g of 500 g	7 g of 100 g
PSSu BP-C1 1/12 C-T	314623	10 g of 500 g	10 g of 100 g
PSSu BP-C1 1/12 S-T	314622	10 g of 500 g	10 g of 100 g
PSSu BP 1/12 C-T	314619	10 g of 500 g	10 g of 100 g
PSSu BP 1/12 S-T	314618	10 g of 500 g	10 g of 100 g
PSSu BP 1/8 C-T	314601	7 g of 500 g	7 g of 100 g
PSSu BP 1/8 S-T	314600	7 g of 500 g	7 g of 100 g
PSSu A EC T	314902	0 g	0 g

## 3 Electromagnetic Compatibility (EMC)

### 3.1 Overview

The PSSu is designed for use within an electromagnetic industrial environment. To ensure electromagnetic compatibility the correct procedures must be carried out when installing the PSSu.

A device is electromagnetically compatible if

- ▶ It functions without error in a given electromagnetic environment.
- ▶ It does not adversely affect its own environment.

Electromagnetic interference can reach the PSSu through:

- ▶ Fields
- ▶ Power supplies
- ▶ Earth cabling
- ▶ Bus connections
- ▶ Interfaces
- ▶ Input and output cables

The interference can be transferred from the source to the receiver (interference sink) via the coupling routes.

Interference reaches the interference sink (e.g. the PSSu) in various ways:

- ▶ DC coupling:  
DC coupling occurs if the source and sink of interference have common cable connections. The common cable presents complex resistances, inducing potential differences.
  - Typical sources of interference are switches/relays, running motors or varying potentials for other systems on the same power supply.
- ▶ Capacitive (electrical) coupling:  
A different potential between the source and interference sink (e.g. two cables) creates an electrical field. Coupling is proportional to the rate of voltage change.
  - Typical sources of interference are contactors, static discharge, parallel signal cables.
- ▶ Inductive (magnetic) coupling:  
A live cable produces a magnetic field which also surrounds adjacent cables. Interference voltage is induced. Coupling is proportional to the rate of current change.
  - Typical sources of interference are mains cables running in parallel, live cables, high frequency cables, inductors, transformers, motors.
- ▶ Electromagnetic coupling  
A cable can emit a signal as a radio wave. This wave is then picked up by another cable.
  - Typical sources of interference are transmitters such as radios, sparks from spark plugs, welding equipment, etc.



#### NOTICE

Powerful HF transmitters should only be operated at a distance of more than 0.6 m.

▶ Static discharge:

Static discharge occurs where there are very high differences in potential between two points. If the two points are brought closer together or if the potential difference is increased, discharges can occur in the air gaps.

- Typical source of interference: people who are statically charged from a synthetic carpet, for example.

## 3.2 Making the installation EMC-compliant

### 3.2.1 Connecting the earth cables

Please note:

- ▶ A conductor cross section of at least 2.5 mm<sup>2</sup> should be used for the connection to the central earth bar. Connections should be kept as short as possible.
- ▶ Connections to the earth bar should always be in star form.
- ▶ Connect together the 0V connections on all the 24 V power supplies and earth the 0 V mains at a single point, or ensure that measures are in place to monitor for earth faults.
- ▶ Earthed supply voltages offer the best noise immunity.
- ▶ The connection of the 0 V supply to the central earth bar or earth fault monitor must be in accordance with relevant national regulations (such as EN 60204-1, NFPA 79, NEC: Article 250).
- ▶ Define a central earthing point.
- ▶ Make sure that the control system and motor are earthed correctly.
- ▶ Earth the mounting plate.
- ▶ Connections should be protected from corrosion.
- ▶ Flexible earthing straps should be used on moving earth parts (e.g. machine parts, gates). Ensure these earthing straps are as short and wide as possible.

### 3.2.2 Cabling

It is possible to differentiate between cables according to their function. The following groups exist:

- ▶ Group 1: Data and supply lines for DC voltages below 60 V and AC voltages below 25 V
- ▶ Group 2: Data and supply lines for DC voltages from 60 V to 400 V and AC voltages from 25 V to 400 V.
- ▶ Group 3: Supply lines above 400 V

Cabling inside buildings

- ▶ The cable groups listed above should be laid separately.
- ▶ Cables of the same group can be laid within the same cable duct.
- ▶ Cables from group 1 and group 2 should be laid in separate groups or in cable ducts which are at least 10 cm apart.
- ▶ Cables from group 1 and group 3 should be laid in separate groups or in cable ducts which are at least 50 cm apart.
- ▶ Data and signal lines should be laid as close as possible to an earthed surface.

Cabling to open air systems

- ▶ As far as possible use metal conduits. These should be electrically connected and earthed.
- ▶ Ensure there is sufficient protection against lightning by using metal conduits earthed at both ends, or concrete cable ducts with reinforcements connected across the joints.

### 3.2.3 Connecting the fieldbuses

Please note:

- ▶ SafetyNET p  
See System Description PSS 4000



#### INFORMATION

To connect the available fieldbus systems, please refer to the operating manual for the respective head module and the guidelines published by the user group or manufacturer.

### 3.2.4 Equipotential bonding

Potential differences may occur if the PSSu system and its periphery devices are connected to different earth connections. Equalising currents can flow through cable shields that are connected at either end and have different earth connections. These equalising currents can cause interference or destroy the cable shield. In order to avoid interference, equipotential bonding cables must be installed. Please note:

- ▶ Select a low impedance equipotential bonding cable.
- ▶ Select the following as standard values for the cross section of the equipotential bonding cables:
  - 16 mm<sup>2</sup> for equipotential bonding cable up to 200 m in length
  - 25 mm<sup>2</sup> for equipotential bonding cable over 200 m in length
- ▶ If the PSSu system and periphery devices are connected with shielded signal cables which are earthed at either end, the impedance is calculated as follows:
  - Impedance equipotential bonding cable = 10 % of shield impedance
- ▶ Use copper or galvanised steel equipotential bonding cable.
- ▶ Connect equipotential bonding cables to the earth bar over as wide a surface area as possible.
- ▶ As short a distance as possible should be kept between the equipotential bonding cable and signal cable.

### 3.2.5 Screening

Interference currents must be diverted to cable shields via shield bars.

Please note:

- ▶ Connect the shields with low impedance to the shield bar or earth bar.
- ▶ Use cables with braided shield, with a minimum cover area of 80 %.

- ▶ When laying cables without equipotential bonding or using foil shields: Connect the shield at one end.
- ▶ If possible, use metal or metallised plugs to connect cables for serial data transfer. Always refer to the regulations relating to the fieldbus systems.
- ▶ If the shield is not to be connected at the end of the cable, it must have no connection to the connector housing.
- ▶ At the point where the cable enters the cabinet, connect the shield to the earth bar, without making a break in the cable. Use metal cable clamps which cover the shield over a wide surface area. Take the screen as far as the PSSuniversal, but do not lay it on top of the PSSuniversal.

Digital inputs and outputs on the PSSu system do not need shielded cables. However, if the connection cables have a shield, it should be connected at one end.

Analogue inputs and outputs plus the inputs and outputs on the counter modules should always be connected using shielded cables.

- ▶ On base modules with C-rail:
  - Connect the shield to the terminals on the C-rail.
  - Connect the C-rail with low impedance to the functional earth.
- ▶ On analogue modules and base modules without C-rail:
  - Connect the shield as shown in the terminal configuration section of the configuration data sheets.
  - The module connects the shield to the functional earth via the mounting rail.

### 3.2.6 Suppression on inductive loads

Suppression should not be used to protect the digital semiconductor outputs.

Digital semiconductor outputs on the PSSuniversal do not need suppression. With FS outputs on the PSSuniversal, suppression can lead to errors on the on/off tests and test pulses.

However, inductive loads that are not switched by the PSSuniversal should be wired with suppression elements for EMC reasons.

### 3.2.7 Installing within an enclosure or wall-mounting

Care must be taken to avoid interference when installing the unit within an enclosure or wall-mounting:

- ▶ Earth bars, earth conductors and the housing should be attached to metal parts in order to divert any coupled interference on to large metal areas. For wall-mounting we recommend: that the overall potential surfaces are made of steel.
- ▶ For varnished or anodised metal parts you should use special contact plates or remove the protective coating.
- ▶ Install an earth bar for the cable shields.
- ▶ The earth bar can also be used as the ground conductor bar.
- ▶ Connect the earth bar or earth conductor to the mounting plate over a wide surface area and with low impedance. If the bar is to be used as the earth conductor, comply with the latest regulations for earthing the bar.

### 3.2.8 Lighting in the control cabinet

Use low interference panel lighting for inside the control cabinet.

## 3.3 Testing the EMC-compliance of an installation

You can use the list below to check that the installation of the PSSu is EMC-compliant.

Check	Action	Done
Are there areas with a high probability of interference? (e.g. computers running, process control areas, distribution cabinets, cable casing, frequency converters, hand-held radios etc.)	EMC protection in these areas should be planned with particular care.	
Are areas where computers are running or areas such as process control rooms sufficiently shielded from electromagnetic coupling?	If necessary shield the whole area.	
Does the cable layout take into account the principles of EMC compliance?	Some important points: Lay cables close to earth, keep clear of other electrical equipment, keep cables in ducts separate from other parts of the installation, keep cables as short as possible.	
Is the supply voltage free of interference?	Supplies with interference voltages should be fitted with a mains filter.	
EMC characteristics of individual units / all units once installed?	Test under operating conditions, e.g. while hand-held radios are in use, or HF frequency generators are close by. Test static discharge with operating personnel, test mutual interference between units under different operating conditions.	
Earthed parts connected correctly?	Most important are the connections to the PSSu housing, racking bars, earth conductors and earth bars; inactive metal parts should be connected over a wide surface area and earthed at a central point; with insulated metal: Remove insulation or use special contact fixings; protect the connection from corrosion; connect the cabinet doors to the body of the cabinet using earthing straps.	
Cable groups laid separately?	Separate cables into groups. Supply and signal leads should be laid separately.	
Are the shields connected correctly?	Use shielded cables for analogue and data leads; use metallic plugs; connect cable shields to shield bar at point of entry to cabinet; connect cable shields over a wide surface area and with low impedance.	
Equipotential bonding carried out?	If the installation extends over a wide area: lay equipotential bonding cable.	

Check	Action	Done
Are inductive loads switched?	Inductive loads that are not switched by digital outputs on the PSSu must be wired with suppression elements.	
24 VDC power supply?	Power supplies must meet the requirements of the standards, such as EN 62368-1 or EN 61010-2-201, for example.	

## 4 Installing the PSSu system

### 4.1 Modular structure

The PSSuniversal is a modular, programmable system for controlling plant and machinery. The PSSuniversal Configurator/PSS 4000 system software is available for configuration. The PSSuniversal Assistant software/Tool Suite PAS4000 provides support when selecting components. A PSSuniversal type system consists of:

- ▶ One head module
- ▶ At least one supply voltage module, if the head module does not have an integrated supply voltage
- ▶ Input/output modules for standard and failsafe applications
- ▶ End bracket to secure the system at the start
- ▶ Terminating plate with integrated bus terminating resistors and end bracket to secure the system at the end

The head module:

- ▶ Connects the sensor/actuator level for standard applications with standard fieldbus systems (e.g. PROFIBUS-DP)
- ▶ Connects the sensor/actuator level for failsafe applications, e.g. with SafetyBUS p or SafetyNET p
- ▶ Co-ordinates the entire process data traffic
- ▶ May have an integrated supply voltage for module supply and periphery supply

Supply voltage modules:

- ▶ Consist of an electronic module and a base module
- ▶ Are available for various functions

Input/output modules:

- ▶ Consist of an electronic module and a base module
- ▶ Are incorporated in a compact module
- ▶ Are available for a wide range of input/output functions
- ▶ Can be installed in any order

Base modules:

- ▶ Are carrier units for the supply voltage modules and input/output modules
- ▶ Are used to connect the field wiring
- ▶ Are available in the following connection types:
  - Spring-loaded terminals or
  - Screw terminals

Electronic modules:

- ▶ Are plugged into base modules.
- ▶ Determine the function of the supply voltage or input/output module
- ▶ Communicate with the head module via the module bus

Compact modules:

- ▶ Incorporate base module and electronic module in one housing

- ▶ Are available in the following connection types:
  - Spring-loaded terminals
- ▶ Communicate with the head module via the module bus

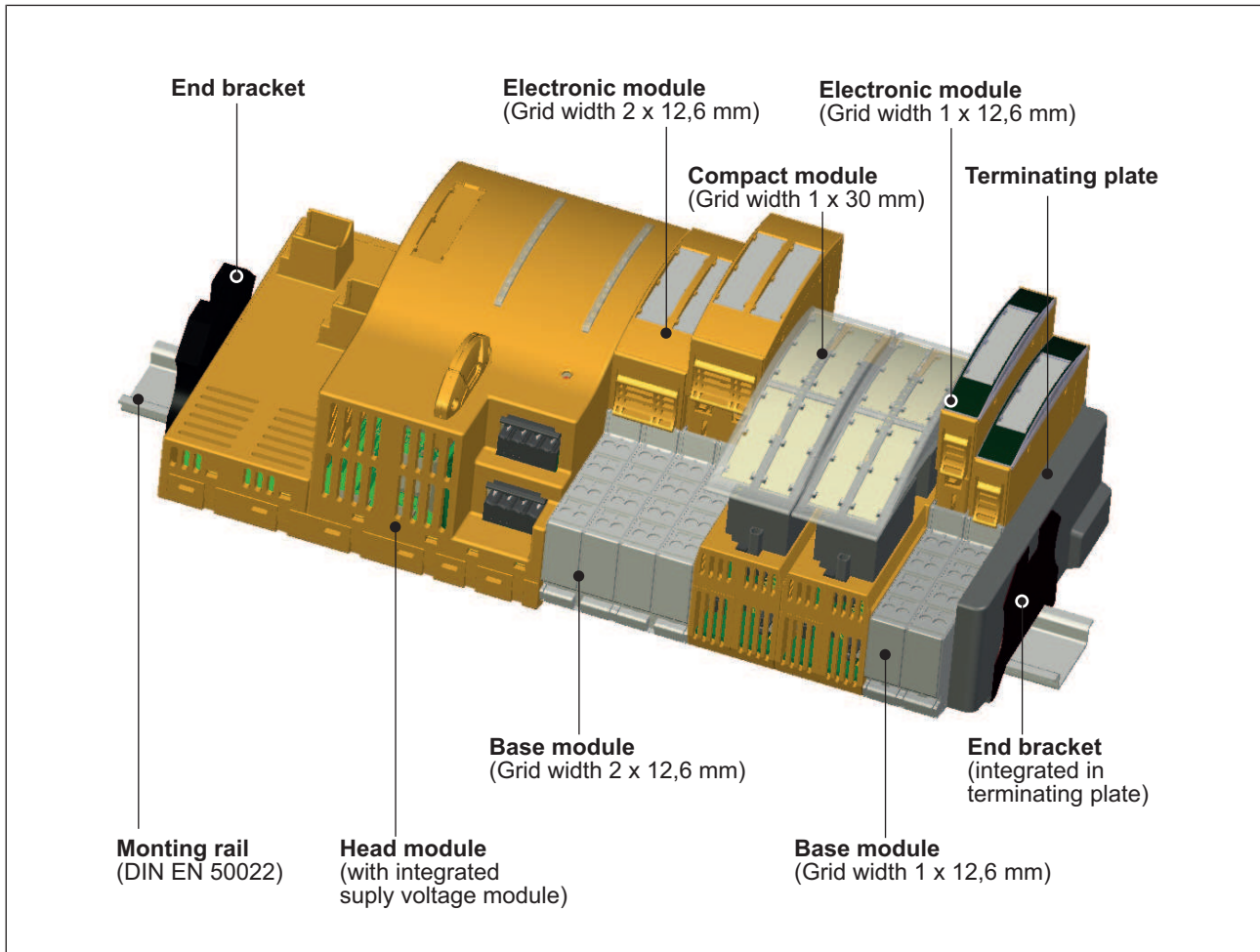

## 4.2 Module layout

- ▶ The first module on a PSSuniversal system is always a head module.
- ▶ If the head module does not have an integrated power supply, a supply voltage module is connected to the right of the head module. The supply voltage module is used
  - To provide the module supply (supply for the head module and the input/output modules)
  - To provide the periphery supply (supply for the sensors and actuators)
- ▶ Input/output modules for FS and ST applications may follow on to the right.
  - The input/output modules may be installed in any order.
  - Input/output modules for FS applications and ST applications may be combined as required.
  - Base modules and electronic modules can be combined with compact modules at will.
  - However, if modules of the same function are combined into groups it makes things clearer and simplifies the wiring.
  - It is not possible to mix base modules with screw terminals and base modules with spring-loaded terminals in one PSSuniversal system.
  - The maximum number of input/output modules is determined through the defined system limits.
  - Input/output modules for FS applications cannot be used on head modules that do not have an FS section.
- ▶ Additional supply voltage modules may be required in order to refresh the module supply or periphery supply.
- ▶ Supply groups require an additional voltage supply module at the start of each group. The modules belonging to the supply group will then follow to the right.
- ▶ The final element in a PSSu system is always a terminating plate containing the terminating resistors for the module bus.
- ▶ The system is attached to the mounting rail using fastening elements at the start and end of the system. The following are available, depending on vibration and shock stress:
  - Plastic version (standard)
  - Metal version (where there is increased stress)

Module layout:

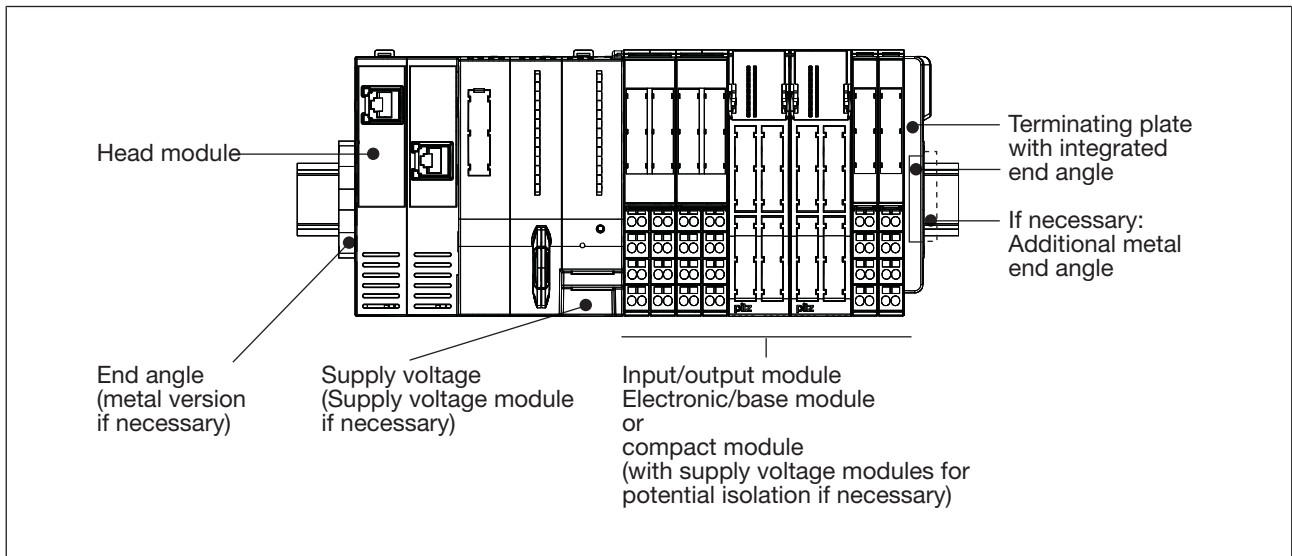

## 4.3 Connection levels

### 4.3.1 Connections on the base modules

The connections on the base modules are divided into connection levels and connection columns. The connections have a two-digit number.

- ▶ The first digit denotes a base module's connection column (e.g.: connection **23** is in the second column).
- ▶ The second digit denotes a base module's connection level (e.g.: connection **23** is in the third level).

The function of the base module connections depends on the electronic module.

### 4.3.1.1 Colour marking on the connection levels

The colour marking on the connection levels is a wiring aid. Various colour markers are available for labelling. The colour markers can be used to label different supplies. This way the connection levels remain clearly visible, even after wiring.

Example:

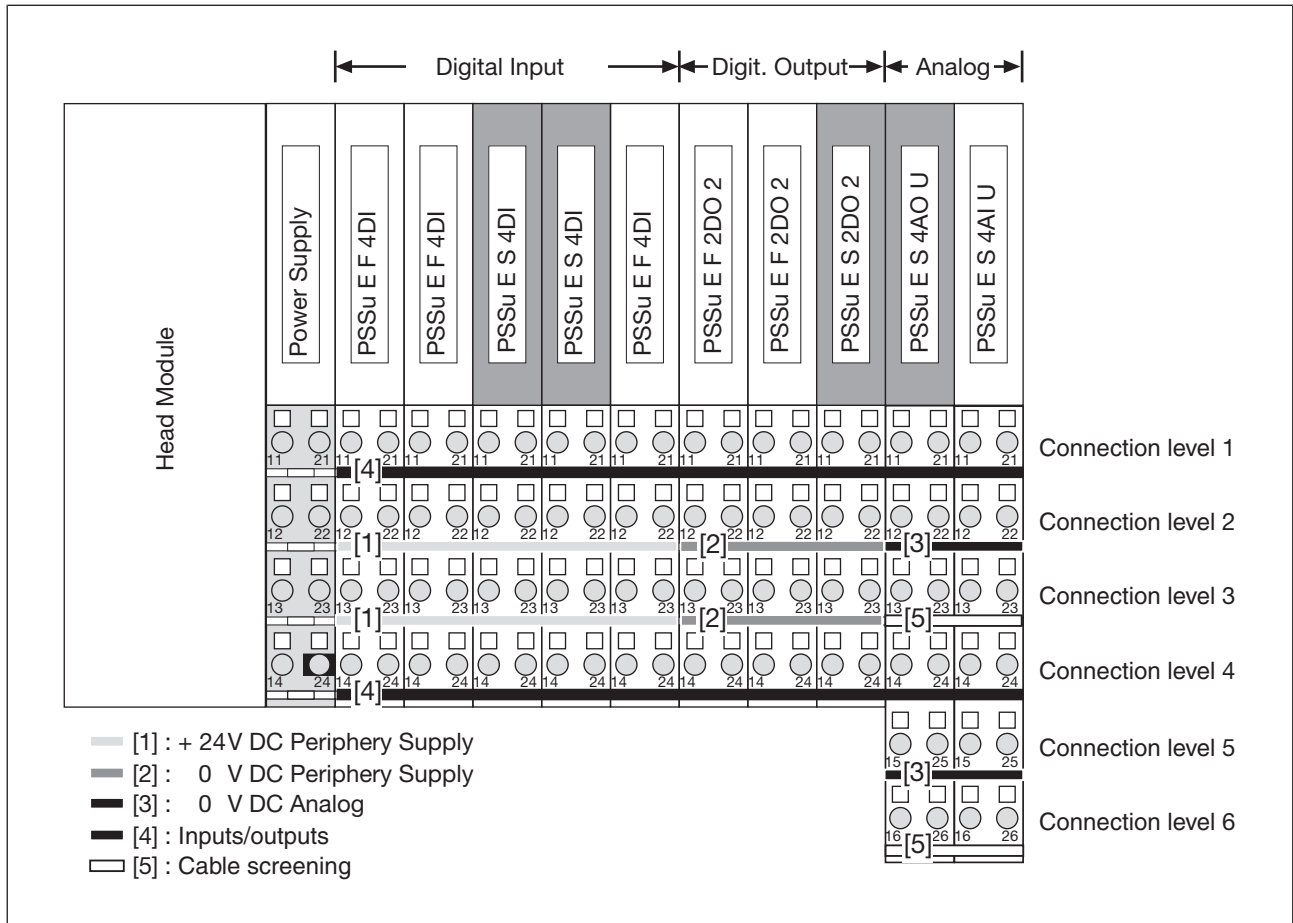

### 4.3.2 Connections on the compact modules

The connections on the compact modules are divided into terminal rows. Single or three-row connectors with spring-loaded terminals can be plugged into the device's single-row 10-pin connector strip.

The function of the connections depends on the compact module.

► Terminal row 1

Connection of the inputs and outputs, periphery supply (24 V and 0 V).

► Terminal row 2

All connections are linked; bridged to the 24 V periphery supply connection from the first connection level

► Terminal row 3

All connections are linked; bridged to the 0 V periphery supply connection from the first connection level

Input/output modules can be installed in any order. However, for the connection diagram to be consistent it makes sense to arrange input/output modules of the same type into groups.

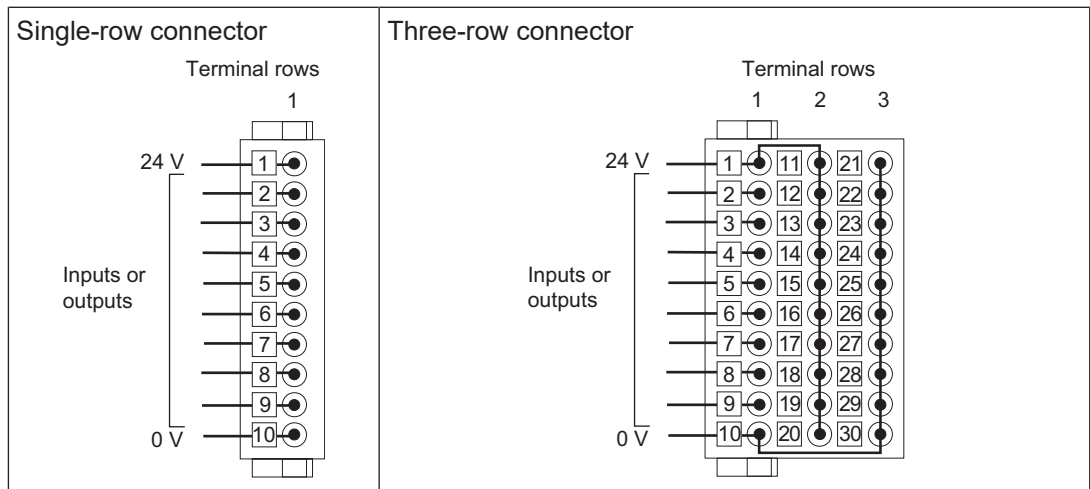

## 4.4 Installation environment

The PSSu system must be installed in a protected environment, e.g. in a control cabinet or a protected interior compartment. The interior compartment must provide protection against environmental influences such as dust and humidity, as well as mechanical damage and manipulation. Please refer to the relevant standards for details of the conditions that must be met for the application.

Use a zinc-plated DIN rail as the mounting rail. Dimensions:

- ▶ 35 x 7.5 mm or 35 x 15 mm

When installing, please note the following:

- ▶ Where vibration and shock stress place increased requirements on the system fastenings, we recommend that the mounting rail is screwed to the mounting plate approximately every 200 mm.
- ▶ We strongly recommend that you comply with the mounting distances stated in the chapter entitled [Mounting distances](#)  24]. This will enable modules to be exchanged and guarantee sufficient heat dissipation.
- ▶ We recommend that it is installed horizontally on a vertical wall.
- ▶ If you wish to install the system vertically, optimum upward heat dissipation is no longer guaranteed. Please note the following restrictions:
  - Reduce the maximum ambient temperature by 10°C compared with the values stated in the technical data.
  - Install the head module downwards.
  - You should use additional metallic end brackets in order to comply with the higher requirements on the system fastenings due to vibration and shock stress.

The T-type PSSu modules are suitable for use where there are increased environmental requirements on temperature and humidity. Please refer to the technical details. With some T-type output modules, please also note the derating at higher temperatures.

#### 4.4.1 Mounting distances

The values shown in the diagram for mounting distances are minimum specifications.

The ambient temperature of the PSSu system in the control cabinet must not exceed the figure stated in the technical details for the modules, Air conditioning may otherwise be required.

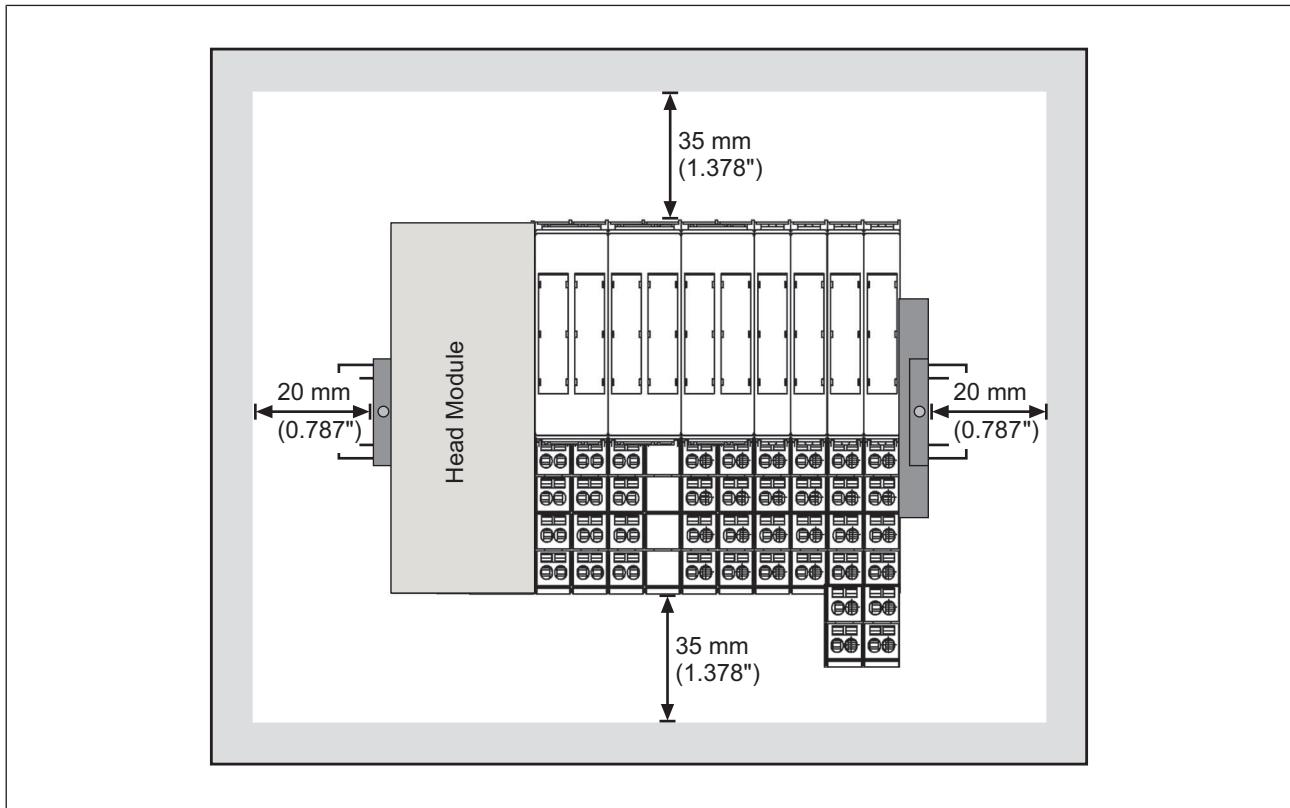

Fig.: Mounting distances when installed horizontally

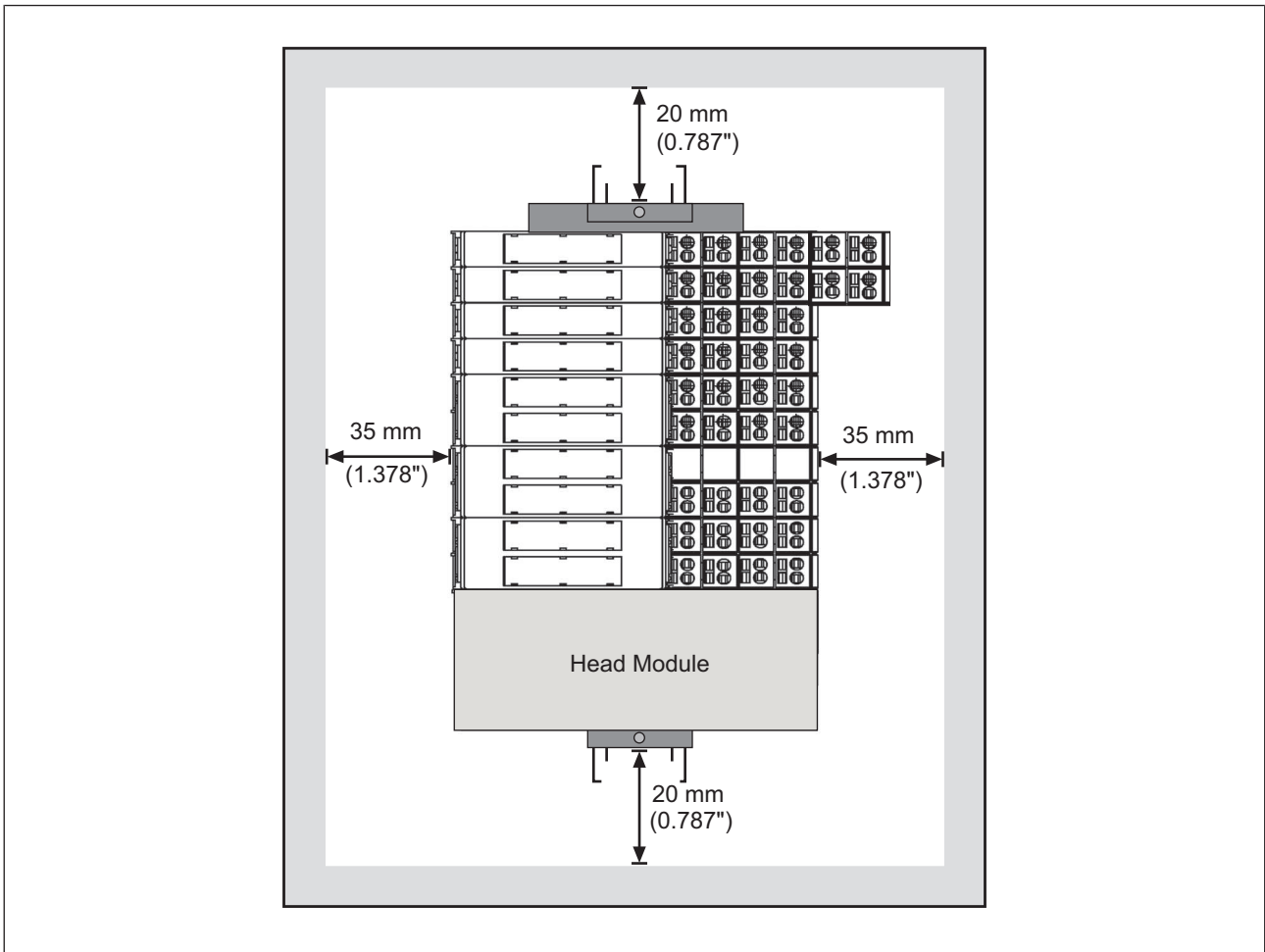

Fig.: Mounting distances when installed vertically

## 4.5 Mechanical coding of the electronic modules

Electronic modules are supplied with a two-part coding element.

When an electronic module is plugged into a base module for the first time, one part of the coding element remains on the electronic module, while its counterpart is fixed on to the base module. This is how the base module is coded.

The coding element is designed to help prevent plugging errors (e.g. when exchanging an electronic module). Once a base module has been coded, it will only take electronic modules with the same mechanical coding.

The coding is identified by a letter and a colour. Codings with the same letters are mechanically identical and are distinguished through a different colour.

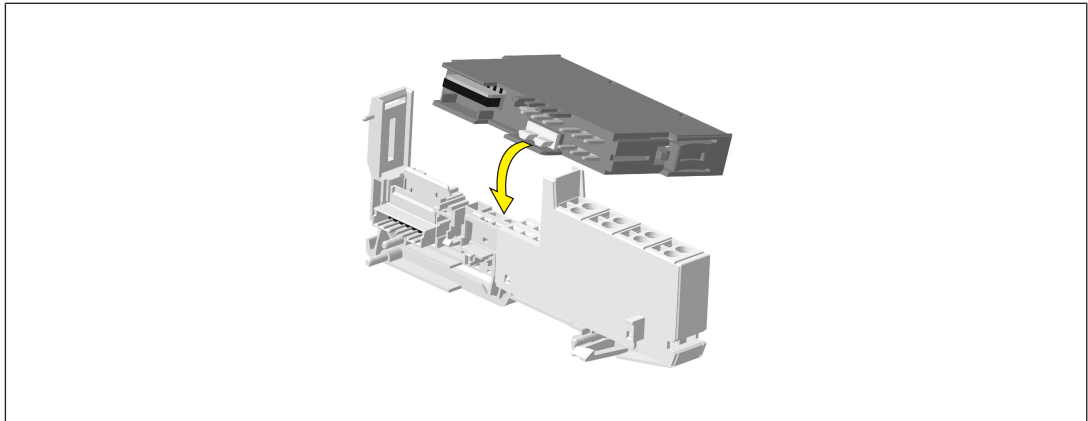













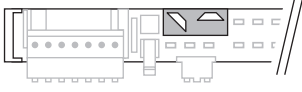

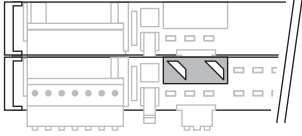

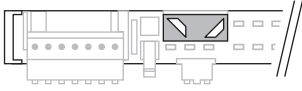
The types of coding elements are listed in the table below.

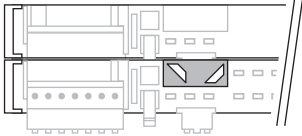
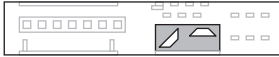
Please note:

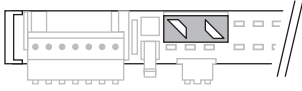
Details of the mechanical coding of the electronic modules (type and colour) can be found in the technical details in the data sheet and operating manual.

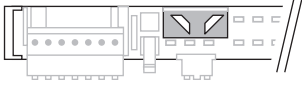
Type	Coding element Electronic module	Coding element on counterpart Base module
A		
B		
C		
D		

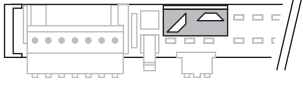
Type	Coding element Electronic module	Coding element on counterpart Base module
E		
F		
G		
H		
I		
		
J		
K		
L		
M		

#### 4.5.1 Removing the mechanical coding from an electronic module

If an electronic module has to be exchanged, the mechanical coding counterpart must be removed from the electronic module. Use flat pliers to remove the counterpart of the coding element.

#### 4.5.2 Removing the mechanical coding from a base module

If an electronic module has to be inserted into a base module that is coded differently, the mechanical coding counterpart must first be removed from the base module.

► Prerequisite

- Base module must be removed from the rail.

► Procedure:

- Use a screwdriver for slotted-head screws (M2).
- Insert the screwdriver into the coding.
- Remove the coding element laterally.

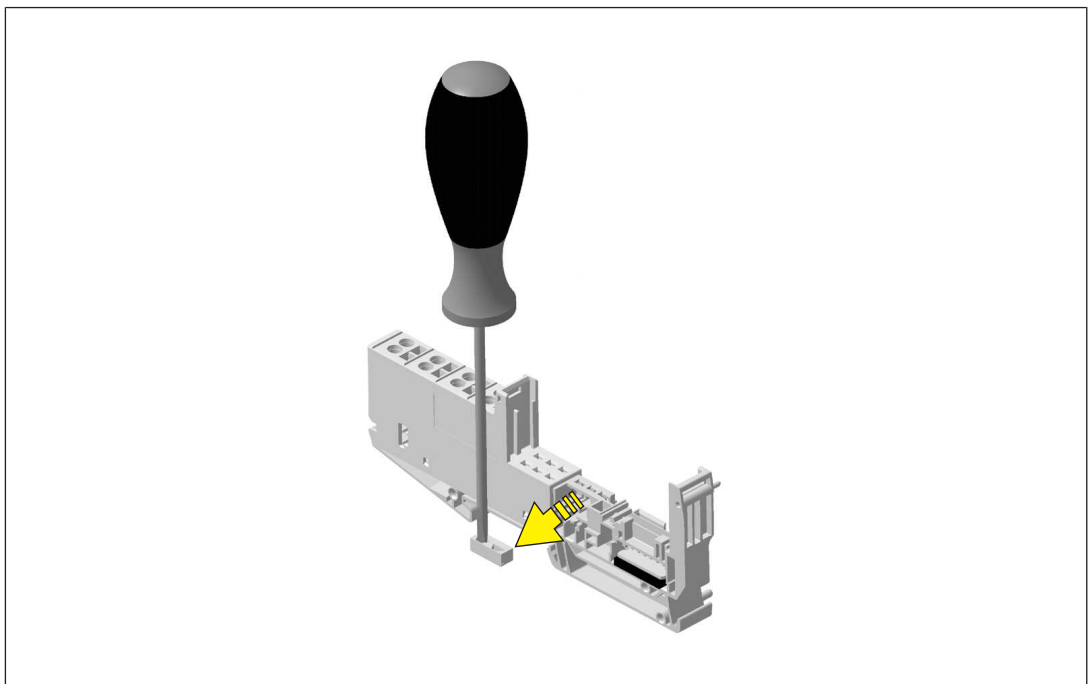
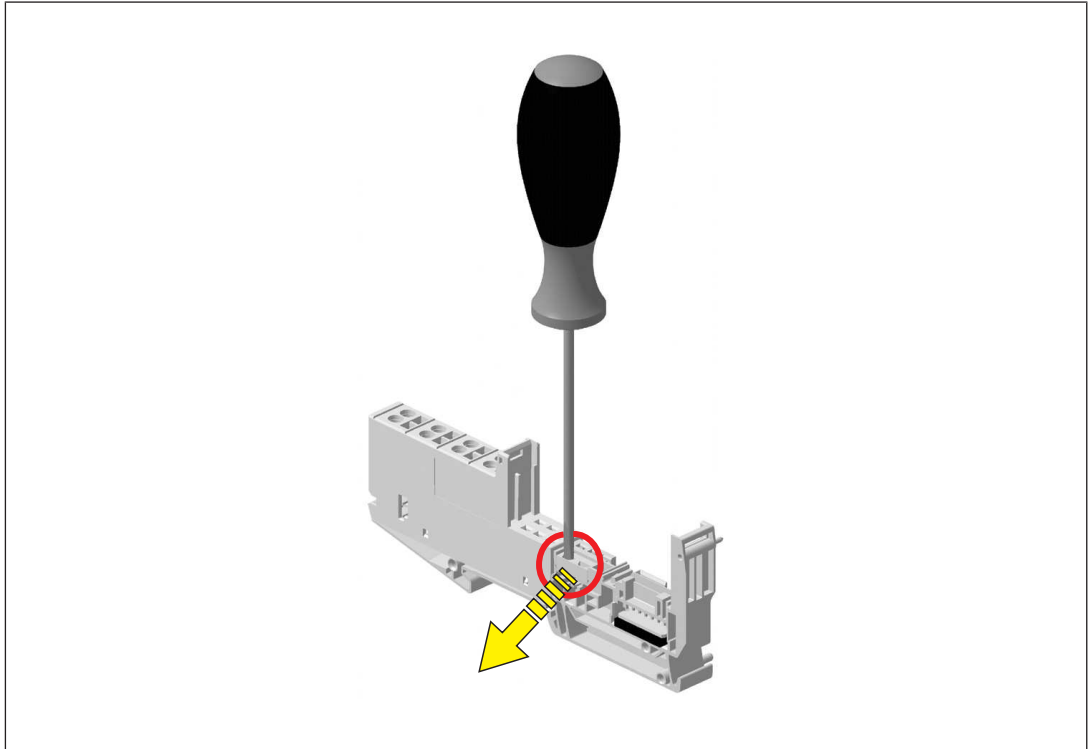

## 4.6 Steps

### 4.6.1 Procedure for installing the PSSuniversal

We recommend the following procedure for installing a PSSuniversal. The individual steps are described in detail on the pages that follow.



#### **WARNING!**

Risk of electrocution!

When voltage is applied, contact with live components could result in serious or even fatal injury from an electric shock.

Switch off all voltages to the connection terminals and power supply prior to installation. You should also switch off all voltages before inserting and removing a connector!

#### Prerequisite

- ▶ The mounting rail must be installed in the control cabinet.

#### Procedure:

- ▶ Install the head module.
- ▶ Install the base modules.
- ▶ Install the compact modules.
- ▶ Install an end bracket on the left.
- ▶ Install an end bracket on the right with a terminating resistor for the module bus.
- ▶ Wire up the base modules with no voltage applied.
- ▶ Connect the plugs for the bus connections to the head module.
- ▶ Insert the electronic modules into the base modules.
- ▶ Plug in the compact module connectors.
- ▶ Commissioning

## 4.6.2 Procedure for removing the PSSuniversal

We recommend the following procedure for removing a PSSuniversal. The individual steps are described in detail on the pages that follow.



### **WARNING!**

Risk of electrocution!

When voltage is applied, contact with live components could result in serious or even fatal injury from an electric shock.

Switch off all voltages to the connection terminals and power supply prior to removal. You should also switch off all voltages before inserting and removing a connector!

Procedure:

- ▶ Remove the plugs for the bus connections on the head module.
- ▶ Remove the compact module connectors.
- ▶ Pull the electronic modules from the base modules.
- ▶ Remove the base module wiring.
- ▶ Remove the end bracket on the right with the terminating resistor.
- ▶ Remove the end bracket on the left.
- ▶ Remove the compact modules.
- ▶ Remove the base modules.
- ▶ Remove the head module.

## 5 Installing the modules

### 5.1 Head modules

#### 5.1.1 Installing the head module

Prerequisite:

- ▶ The mounting rail must be installed.

Procedure:

- ▶ Install an end bracket to the left of the head module or leave enough space for one.
- ▶ Slot the groove on the head module on to the mounting rail from below [1].
- ▶ Push the head module back [2] until you hear it lock into position.

Schematic representation:

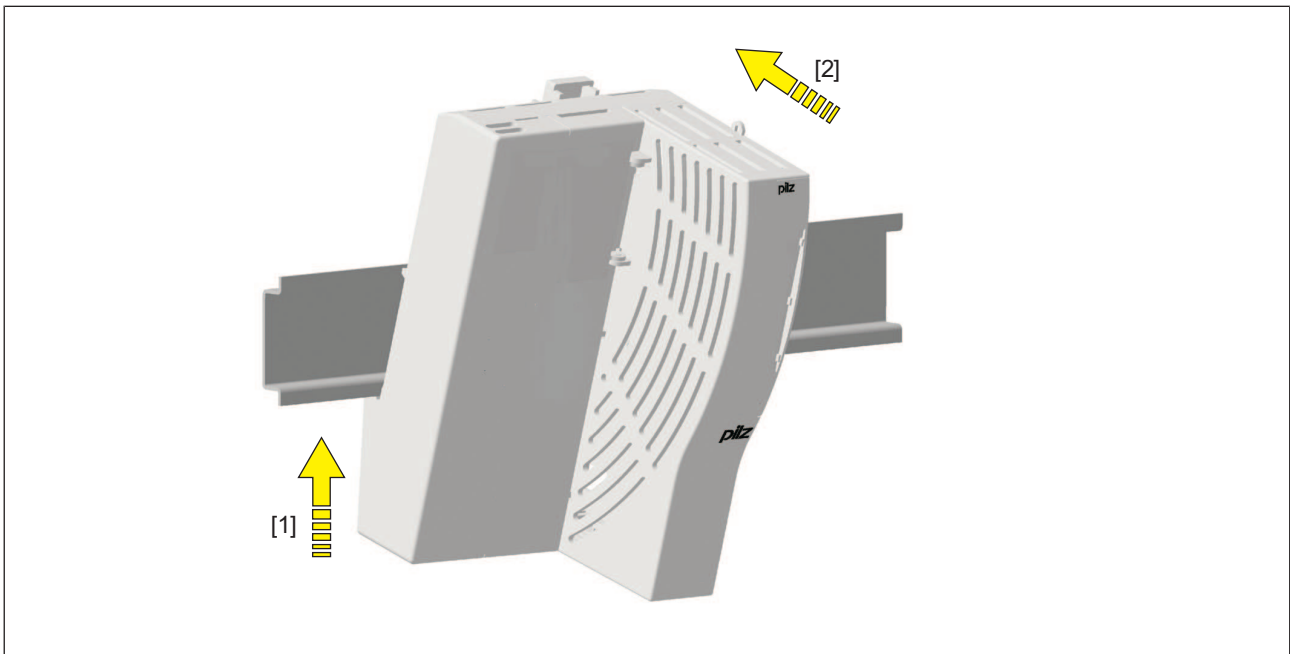

### 5.1.2 Removing the head module

Prerequisite:

- ▶ The supply voltage must be switched off.
- ▶ The plugs for the bus connections must be removed.
- ▶ All the wiring must be removed
- ▶ All the base modules and compact modules must have been moved to the right (min. 30 mm) or have been removed from the rail.

Procedure:

- ▶ Using a screwdriver, push the rear locking element [1] upwards until the locking hook releases the anchor.
- ▶ Pivot the head module and screw driver forwards [2] and remove in a downward direction [3].

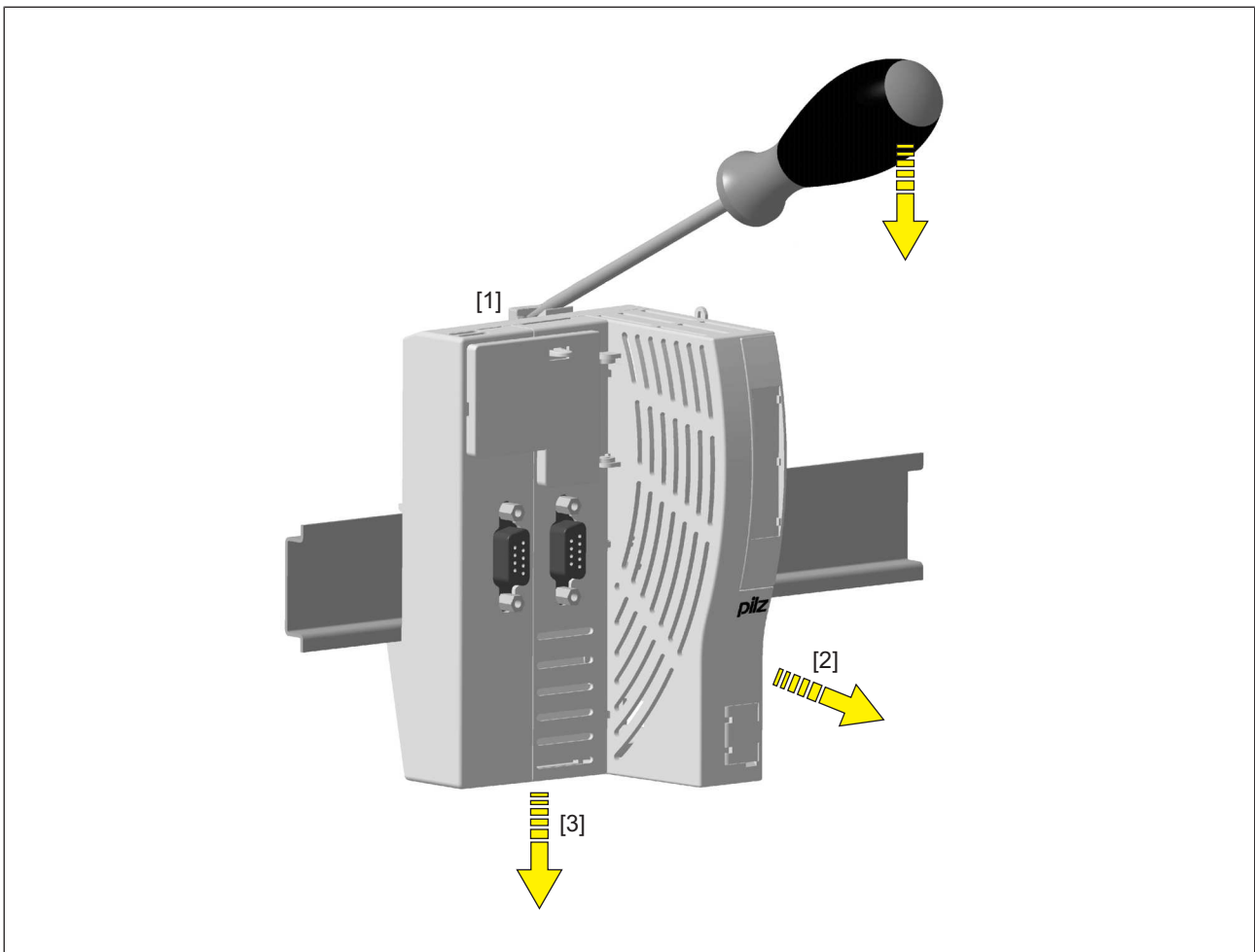

## 5.2 Base modules

### 5.2.1 Installing base modules

Prerequisite:

- ▶ The head module must be installed.
- ▶ If the head module does not have an integrated power supply, a supply voltage module must be installed to the right of the head module.

Please note:

- ▶ For mechanical reasons it is not possible to mix base modules with screw terminals and base modules with cage clamp terminals.
- ▶ All contacts should be protected from contamination.
- ▶ The mechanics of the base modules are designed for 50 plug in/out cycles.

Procedure:

- ▶ We recommend that you wire up the base modules before inserting the electronic modules.
- ▶ Slot the groove on the base module on to the mounting rail from below [1].
- ▶ Push the base module back [2] until you hear it lock into position.
- ▶ On the mounting rail, slide the base module to the left until you hear the two lateral mounting hooks on the adjacent module lock into position [3].

Schematic representation:

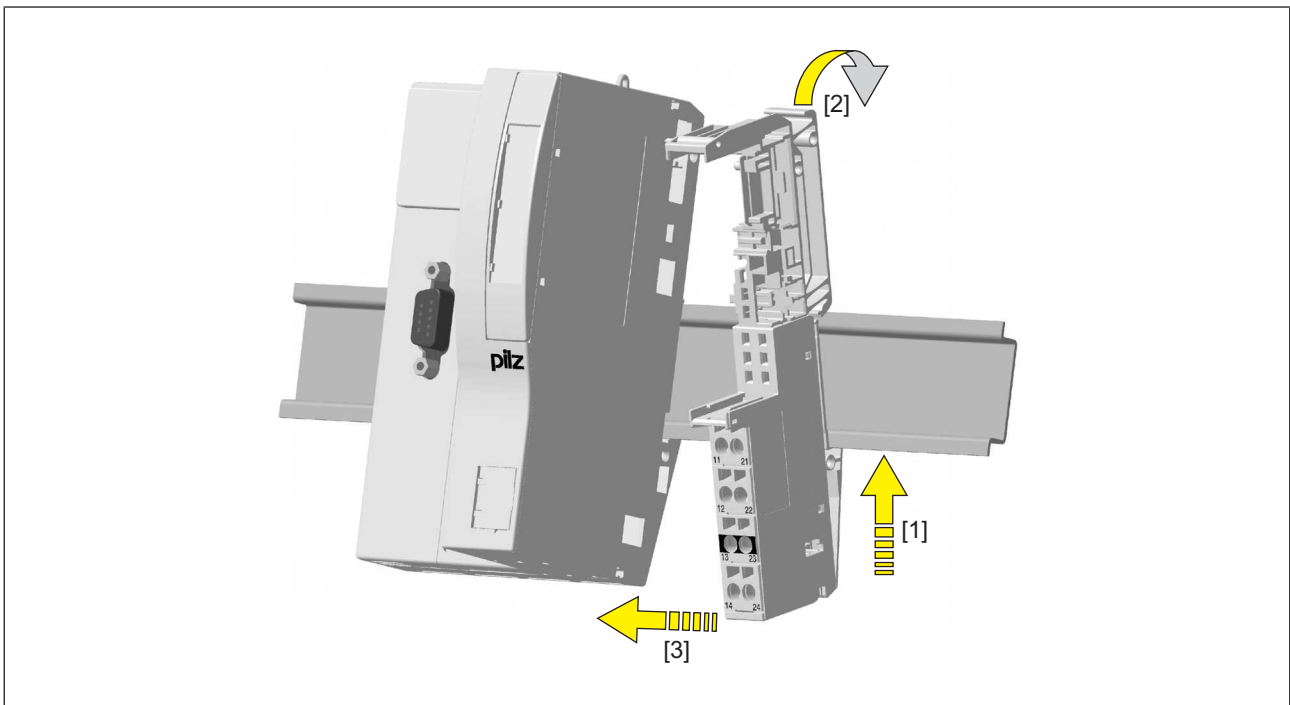

## 5.2.2 Removing base modules

### Prerequisite

- ▶ The supply voltages must be switched off.
- ▶ All the wiring must be removed
- ▶ The electronic module on the relevant base module must have been removed, plus the electronic module on the base module to its left.
- ▶ All the base modules and compact modules to the right of the relevant base module must have been moved to the right (min. 30 mm) or have been removed from the rail.

### Procedure:

- ▶ Insert the screwdriver into the square mounting hole on the base module to the left [1] of the relevant module.
- ▶ Push the screwdriver downwards and keep it pressed down.
- ▶ Use the other hand to pull the base module to the right [2] until the locking element on the base module you are removing is completely free.
- ▶ On the mounting rail, slide the base module to the right [3]
- ▶ Using a screwdriver, push the rear locking element [4] upwards [5] until the locking hook releases the anchor.
- ▶ Pivot the base module and screw driver forwards and remove in a downward direction.

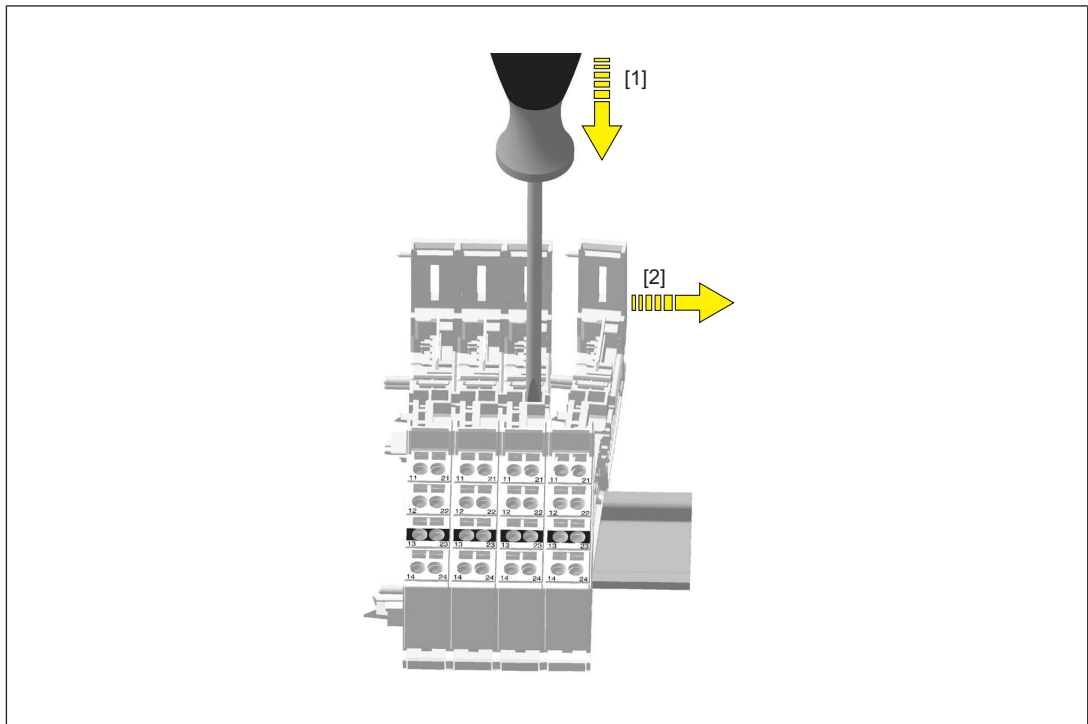

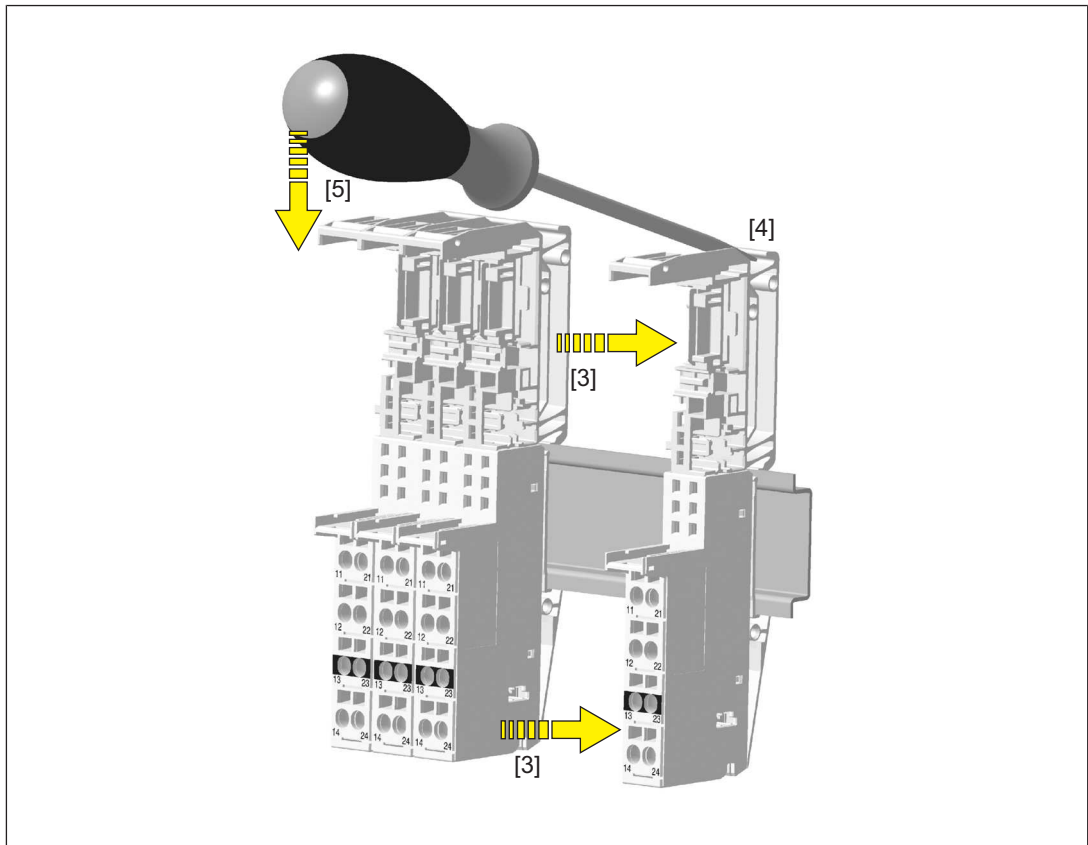

## 5.3 Electronic modules

Please note:

- ▶ Only insert on to base modules that are already installed.
- ▶ Preferably these base modules should be ready wired.
- ▶ Electronic modules with outputs may only be inserted and removed when the load is switched off. Unforeseeable error reactions may be triggered if modules are inserted and removed under load.
- ▶ When an electronic module is plugged into a base module for the first time, one part of the coding element remains on the electronic module, while its counterpart is fixed on to the base module. This is how the base module is coded.
- ▶ The mechanics of the electronic modules are designed for 50 plug in/out cycles.

### 5.3.1 Inserting an electronic module

Procedure:

- ▶ The electronic module must audibly lock into position [1].
- ▶ Mark the electronic module using the labelling strips [2].

Schematic representation:

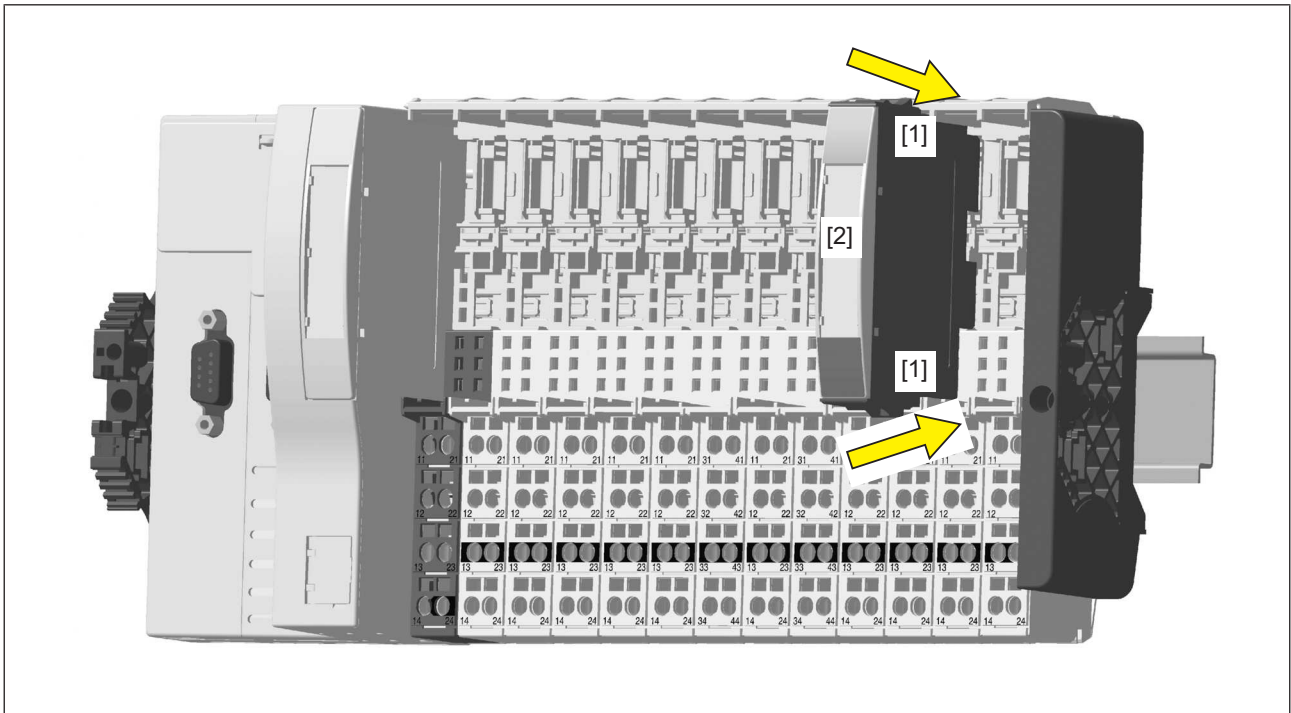

## 5.3.2 Removing an electronic module

Procedure:

- ▶ Press the locking mechanisms [1] together simultaneously.
- ▶ Pull out the electronic module [2].

Schematic representation:

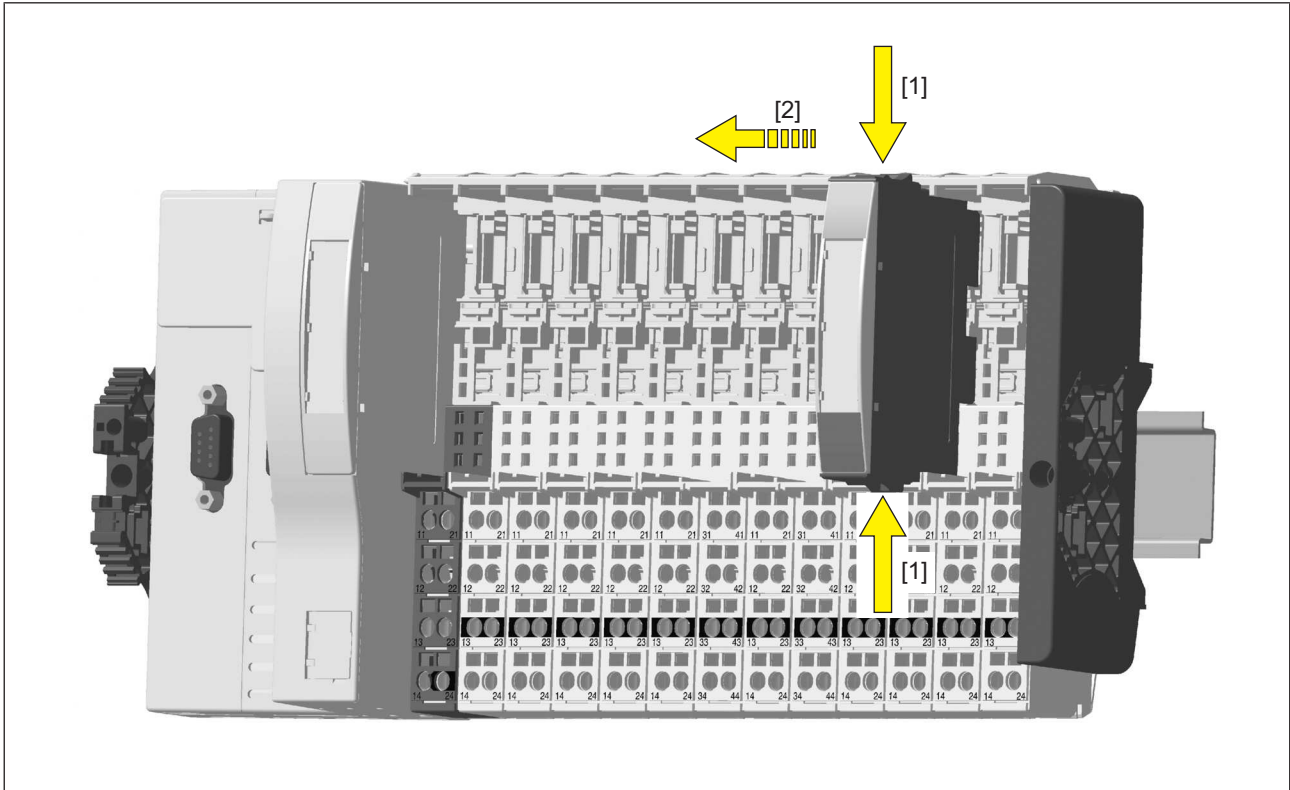

## 5.4 Compact modules

### 5.4.1 Install the compact modules

Prerequisite:

- ▶ The head module must be installed.
- ▶ If the head module does not have an integrated power supply, a supply voltage module must be installed to the right of the head module.
- ▶ A base module with screw terminals may not be installed to the left of the compact module.

Please note:

- ▶ All contacts should be protected from contamination.
- ▶ The mechanics of the compact modules are designed for 50 plug in/out cycles.

Procedure:

- ▶ Slot the groove on the compact module on to the mounting rail from below [1].
- ▶ Push the compact module back as far as it will go [2].

- ▶ Make sure that the locking mechanism [3] is pushed downwards, connecting the module firmly to the mounting rail.
- ▶ On the mounting rail, slide the compact module to the left.



**NOTICE**

**Potential contact damage due to twisting!**

The contacts for the Module Supply and Periphery Supply can be bent by twisting the compact modules on the mounting rail.

- On the mounting rail, carefully slide the compact module to the left, in parallel to the adjoining module, until you hear the lateral mounting hooks on the adjacent module lock into position [4].

Schematic representation:

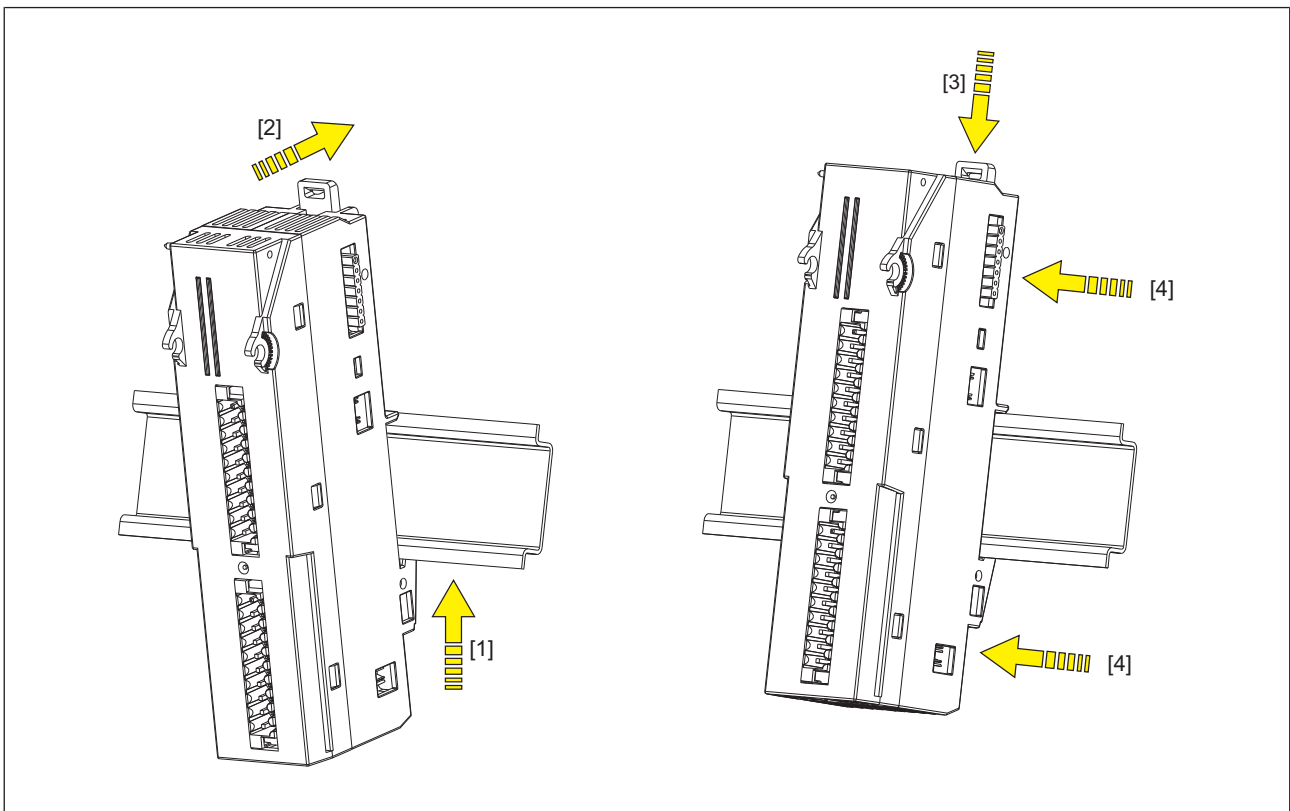

## 5.4.2 Remove the compact modules

### Prerequisite

- ▶ The supply voltages must be switched off.
- ▶ All the wiring must be removed
- ▶ All the compact modules to the right of the relevant base module must have been moved to the right (min. 30 mm) or have been removed from the rail.

### Procedure:

- ▶ Pull out the locking mechanism [1]
- ▶ Pull the compact module to the right [2] until the locking element on the relevant compact module is completely free.
- ▶ On the mounting rail, slide the compact module to the right.
- ▶ Pivot the compact module forwards [3] and remove in a downward direction [4].

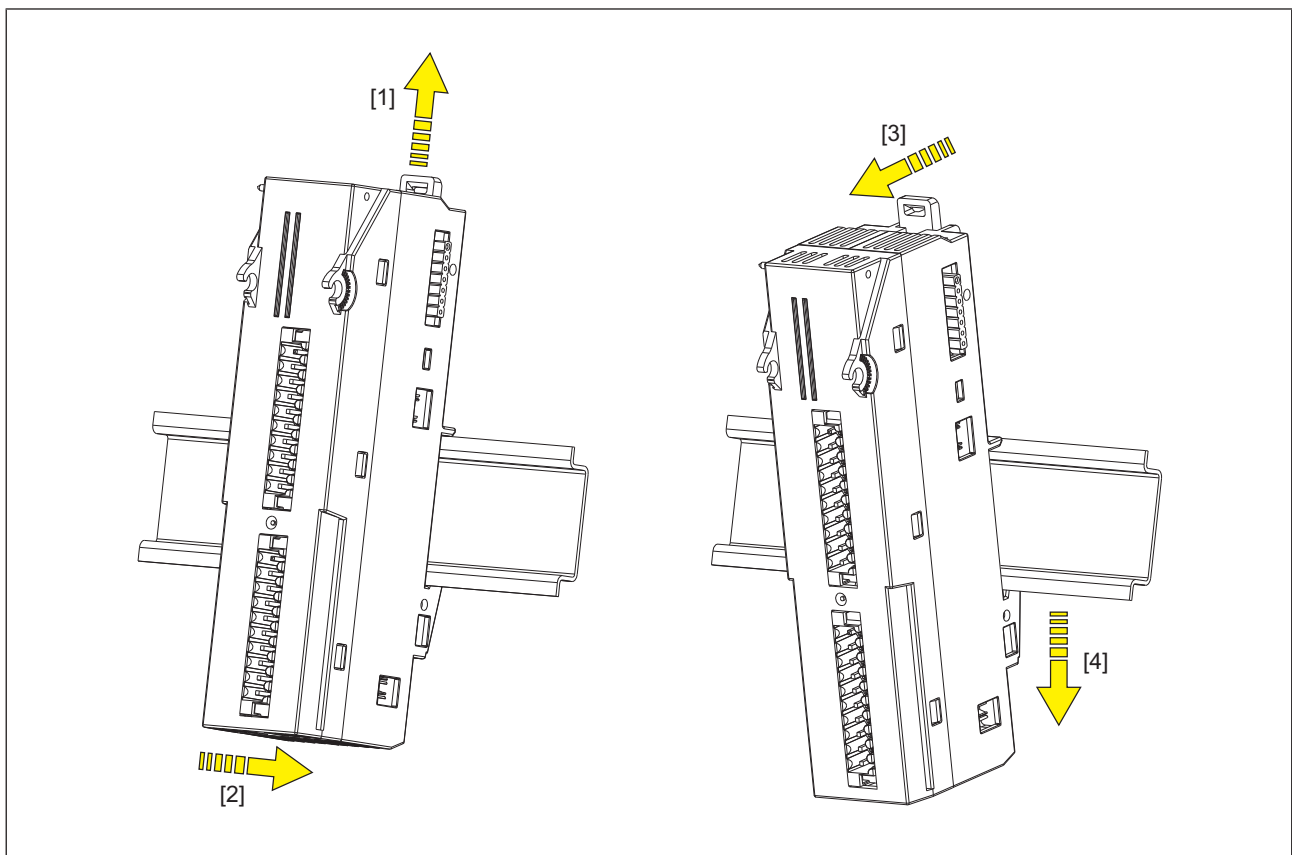

## 5.5 End bracket

### 5.5.1 Install an end bracket on the left

Procedure:

- ▶ Use a screwdriver for slotted-head screws (M2).
- ▶ Loosen the fixing screw on the end bracket until the terminals are far enough apart for the end bracket to be positioned on the mounting rail.
- ▶ Place the end bracket on the mounting rail, to the left of the head module [1].
- ▶ Slide the end bracket up close to the head module [2]
- ▶ Tighten up the end bracket [3].

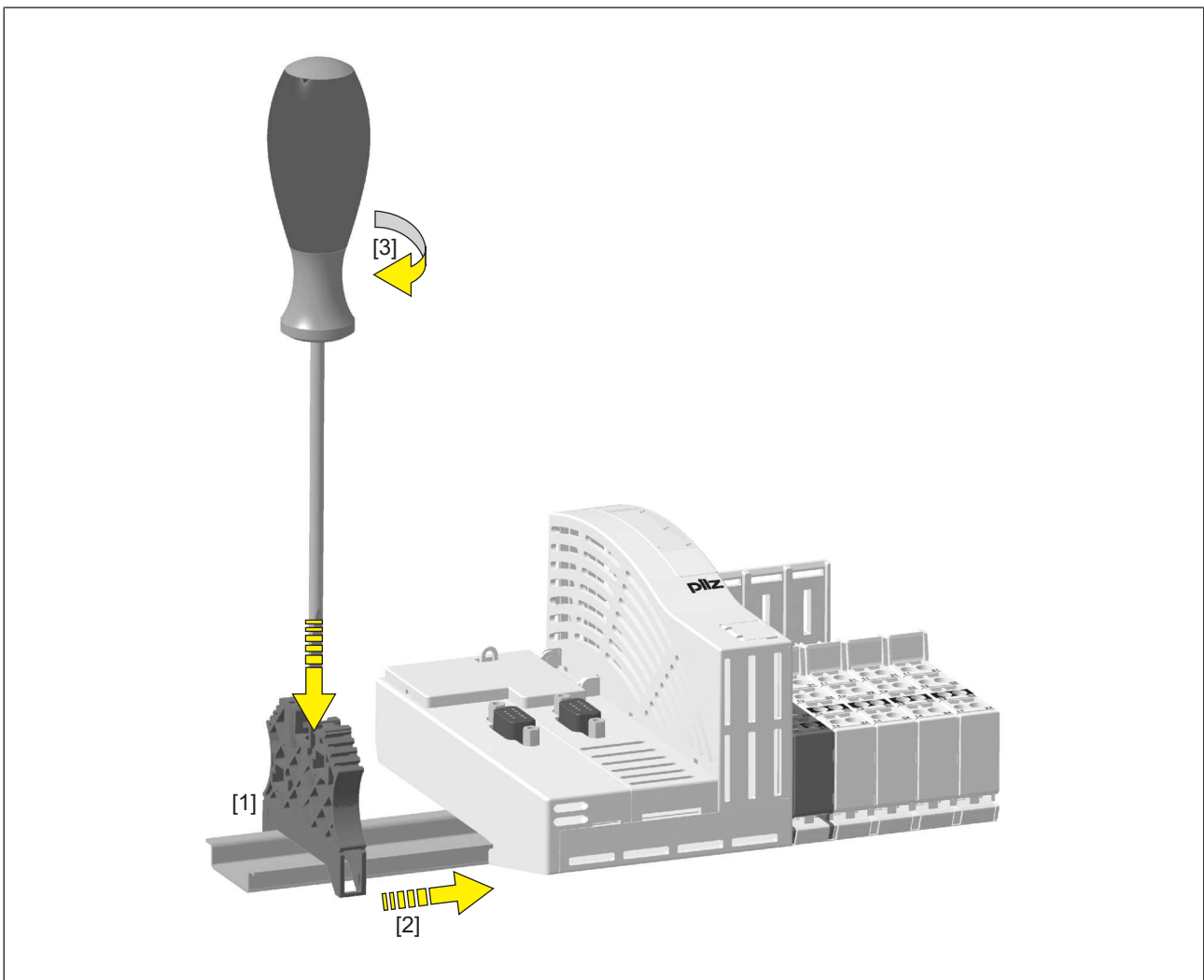

## 5.5.2 Install a connection plate on the right

Procedure:

- ▶ Use a screwdriver for slotted-head screws (M2).
- ▶ Attach the terminating plate to the mounting rail as the final element on the system [1].
- ▶ Loosen the fixing screw on the end bracket until the terminals are far enough apart for the end bracket to be positioned on the mounting rail.
- ▶ Place the end bracket on the mounting rail, to the right of the terminating plate [2].
- ▶ Slide the end bracket and terminating plate into each other [3]
- ▶ Slide the terminating plate with integrated end bracket up to the final base module as far as it will go [4]; ensure that contact is made with the integrated bus terminating resistors.
- ▶ Insert the screwdriver into the terminating plate [5]
- ▶ Tighten up the integrated end bracket [6].

If an additional metallic end bracket is required to secure the system, this additional end bracket is installed to the right of the terminating plate.

Procedure:

- ▶ Loosen the fixing screw on the metallic end bracket
- ▶ Place the metallic end bracket on the mounting rail
- ▶ Slide the metallic end bracket up close to the terminating plate with the integrated end bracket
- ▶ Tighten up the metallic end bracket

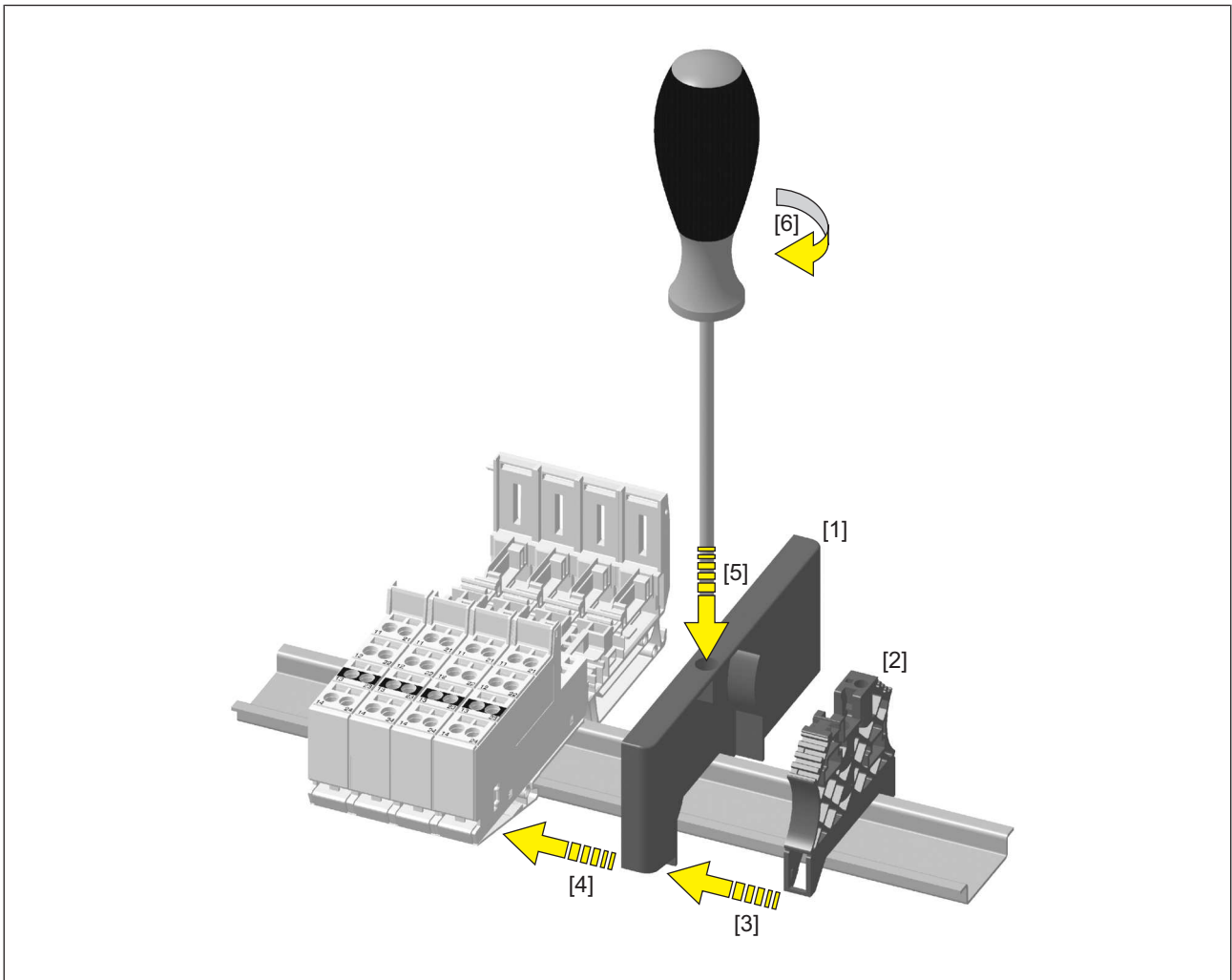

### 5.5.3 Remove the end bracket on the left

Procedure:

- ▶ Use a screwdriver for slotted-head screws (M2).
- ▶ Loosen the fixing screw on the end bracket until the terminals' clamping force is lifted.
- ▶ Remove the end bracket from the mounting rail.

### 5.5.4 Remove the connection plate on the right

Procedure:

- ▶ Use a screwdriver for slotted-head screws (M2).
- ▶ Insert the screwdriver into the terminating plate [1]
- ▶ Loosen the fixing screw on the end bracket [2].
- ▶ Move the terminating plate and integrated end bracket to the right [3].  
Please note: Do not damage the elements used to connect to the adjacent base module.
- ▶ Loosen the fixing screw on the end bracket until the terminals' clamping force is lifted.
- ▶ Remove the terminating plate and integrated end bracket from the mounting rail.

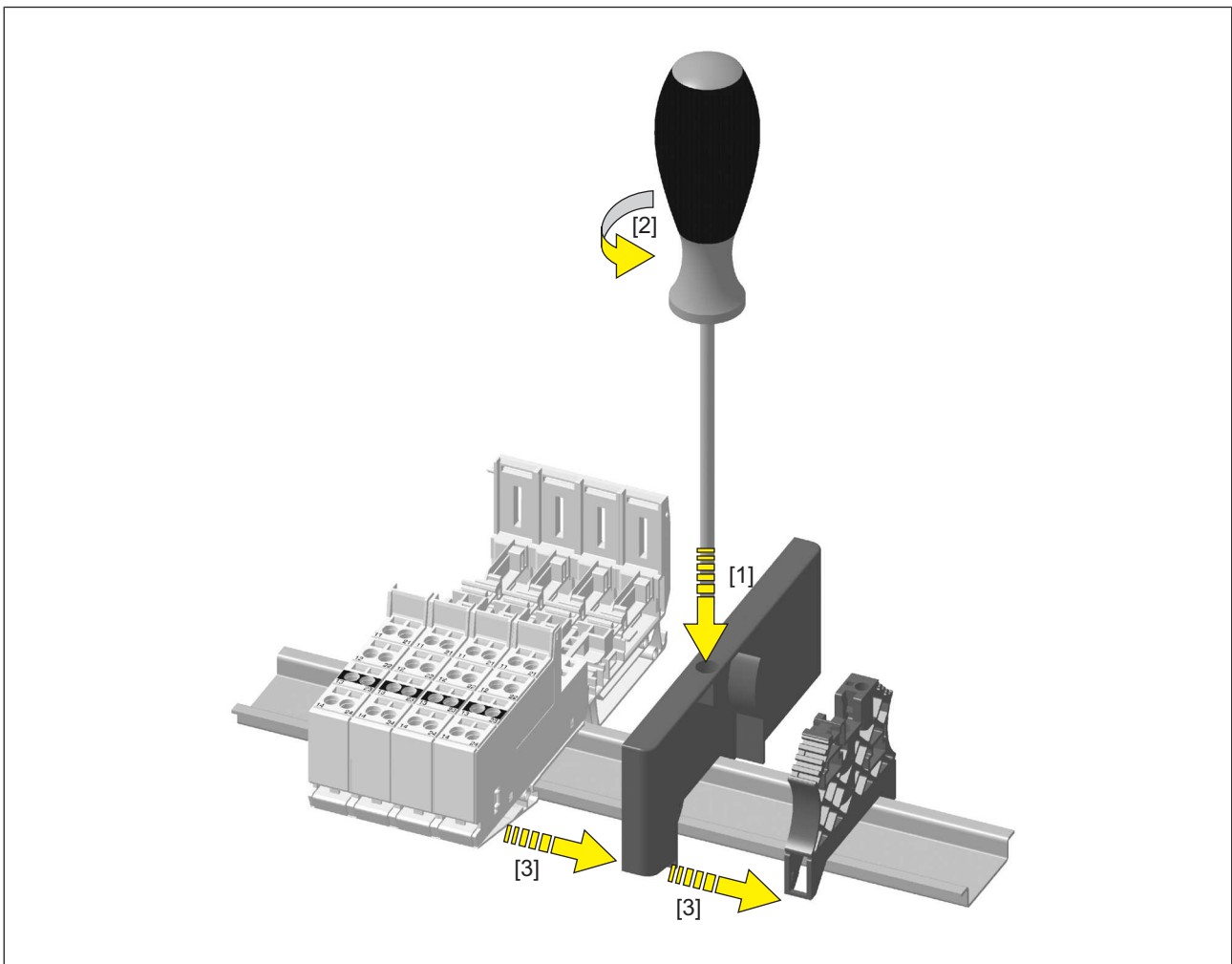

## 6 Connecting the PSSu system

### 6.1 Supply voltages

All PSSu system voltages are supplied via the head module or via supply voltage modules. If the supply voltage is not integrated within the head module, a separate supply voltage module will be required. The voltages are distributed to the modules via the module bus.

▶ **Module supply**

The module supply is the internal supply voltage for the head module, the compact modules and the electronic modules.

▶ **Periphery supply**

The periphery supply supplies 24 VDC to the sensors and actuators on digital input/outputs on electronic modules. On compact modules, the supply for the inputs is generated from the periphery supply; the supply for the outputs must be fed to the module terminals.

The periphery supply can be disconnected in order to form supply groups. On digital failsafe modules, the periphery supply is used to provide test pulses. Failsafe input/output modules will not start until the periphery supply is connected correctly. On analogue input/output modules, the periphery supply is galvanically isolated from the inputs/outputs.

▶ **C-rail**

The C-rail is an additional, free power rail. Access to the C-rail is available via base modules that contain "-C" in their description (e.g. PSSu BP-C 1/8 S, PSSu BP-C 1/8 C).

The C-rail supply must belong to the same circuit as the other base module connections. Connecting PE to the C-rail provides a simple form of shielding. On the compact modules, the C-rail is not looped through and is not available at the terminals. Permitted in-feed at the C-rail:

- PE
- 0 V
- Shield
- - 30 VDC ... + 30 VDC
- - 48 VAC ... + 48 VAC

▶ **Inputs/outputs on the analogue modules and counter modules**

The inputs and outputs on the analogue modules and counter modules are galvanically isolated from the periphery supply. On the base modules, the supply for the outputs is generated from the periphery supply.

▶ **Earth (ground)**

The module supply and periphery supply have separate connections for the respective earth potential (Ground).

▶ **Functional earth**

A contact spring on the base modules and compact modules connects the modules' functional earth to the mounting rail.

The supply voltages for the module supply and periphery supply must be functional extra low voltages with safe electrical separation (PELV or SELV). The external power supplies must comply with EN 62368-1 and EN 61010-2-210. Further requirements of the power supplies can be found in the data sheets for the supply voltage modules or head modules.

When the voltages are fed separately using two power supplies, the module supply and periphery supply are galvanically isolated. If galvanic isolation is not required, a common power supply may be used for the periphery supply and module supply.

Separate power supplies for module supply and periphery supply increase availability: In the case of a short circuit in the periphery supply, the module supply is maintained and the head module can continue to exchange data with fieldbus systems, e.g. for diagnostic purposes.



**WARNING!**

Risk of electrocution!

Always connect the mounting rail to the protective earth via an earthing terminal. This will be used to dissipate hazardous voltages in the case of a fault.

A base-insulated device with a supply voltage of more than 50 VAC or 120 VDC may not be connected parallel to the module supply.

Insulation of supplies in a PSSu installation:

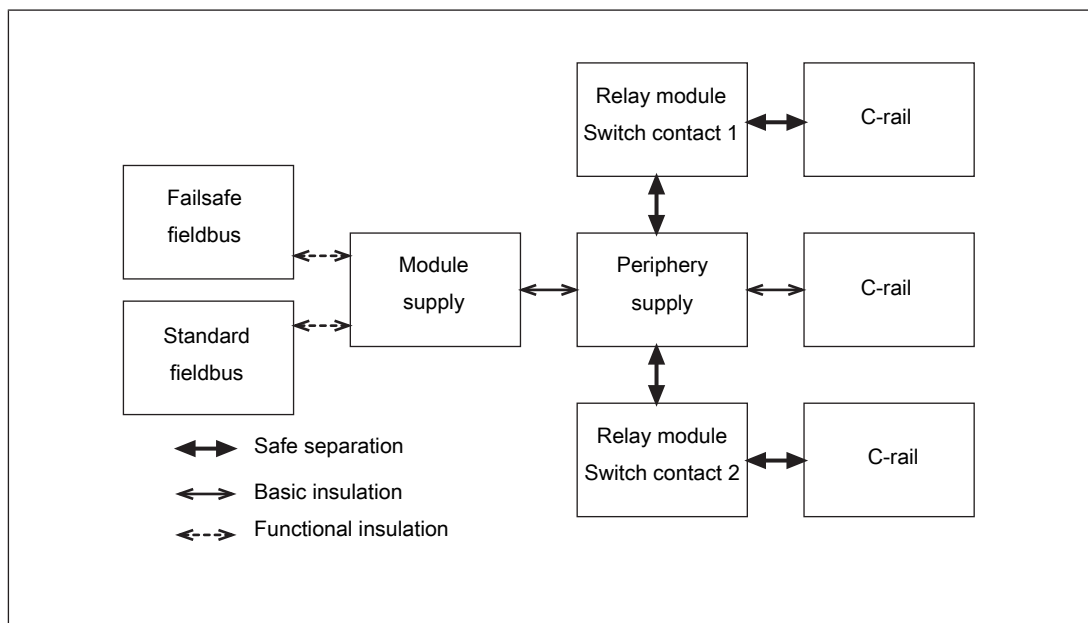

**WARNING!**

Risk of electrocution!

If voltages higher than 50 VAC or 120 VDC are connected to the PSSuniversal, e.g. to switch contacts on relay modules, please note the following:

- Specific accident prevention regulations apply.
- The C-rail of the supply group should only be connected to the protective earth (PE).

## 6.2 Power supplies

Please note:

- ▶ The external power supplies must comply with the current applicable standard EN 62368-1 or EN 61010-2-201.
- ▶ Use in furnaces in accordance with EN 298:  
To protect against transient power failures (EN 61000-4-29) the DC power supply used for the system must provide secondary buffering for at least 30 ms.
- ▶ On supply groups with an earthed supply: The module supply and periphery supply require a common 0 V reference potential.
  - Connect together the 0 V connections on all the external power supplies and earth the 0 V mains at a single point.
  - Earthed supply voltages offer the best noise immunity.
- ▶ On floating supply groups: Do not earth the 0 V supply on the module supply and periphery supply.
  - Please note the regulations on insulation monitoring and safe electrical isolation.
  - The 0 V supply on the module supply is always looped through across the whole module bus of a PSSu system, even when the supply groups are different.
- ▶ The connection of the 0 V supply to the central earth bar or earth fault monitor must be in accordance with national regulations (e.g. EN 60204-1, NFPA 79:17-7, NEC: Article 250).

Example 1: Module supply and periphery supply from separate power supplies, earthed supply group.

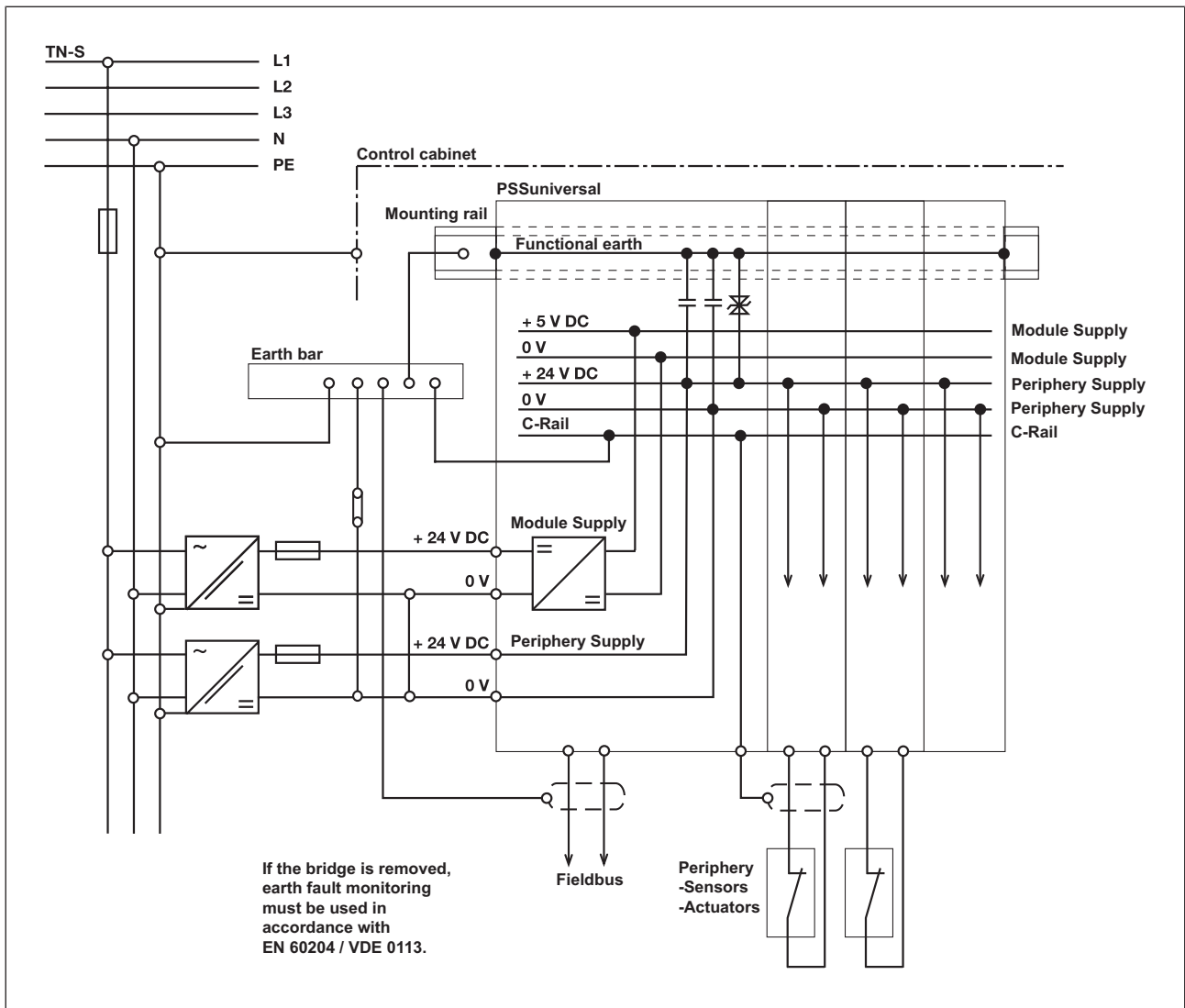

Example 2: Module supply and periphery supply from separate power supplies, floating supply group.

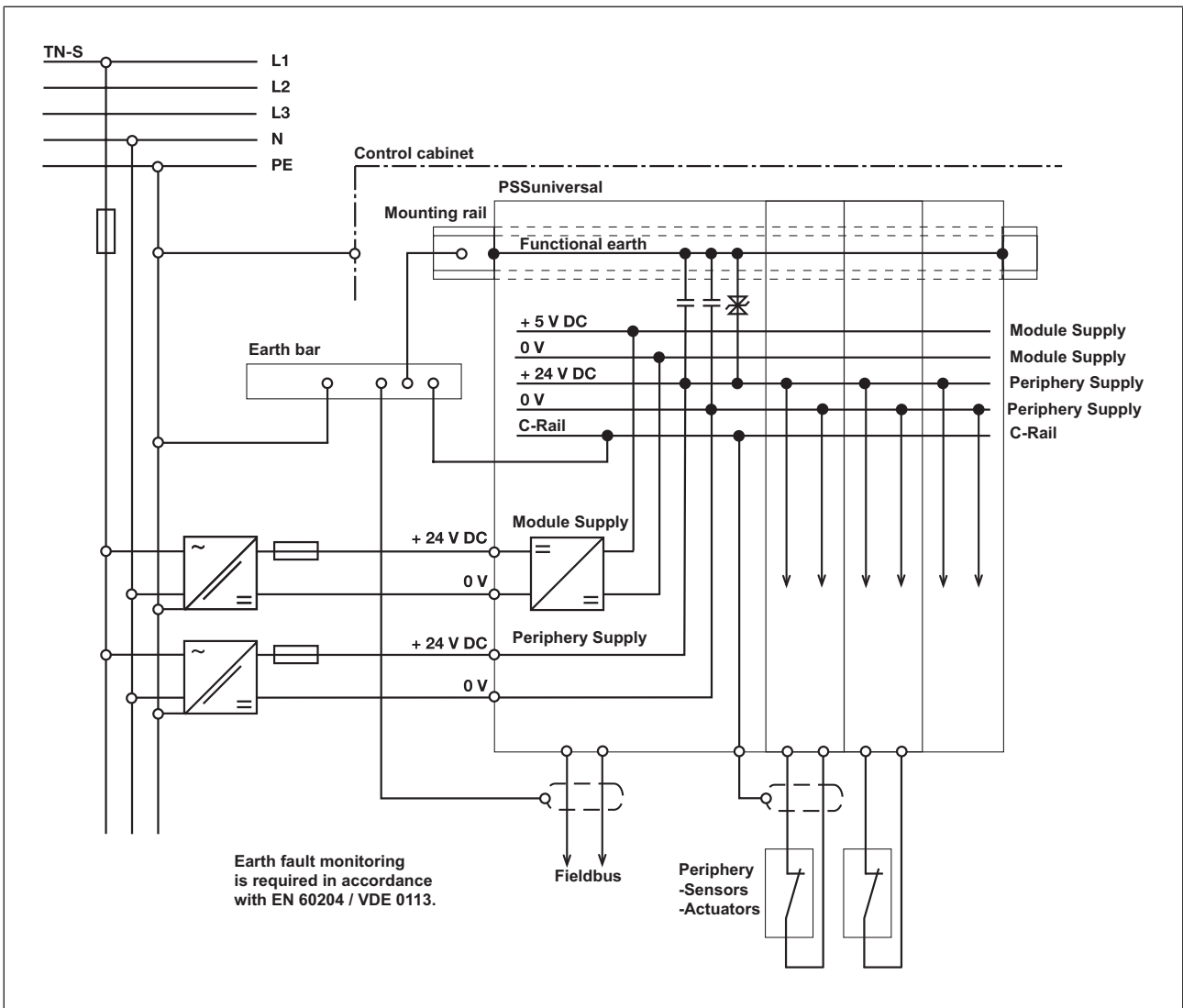

Example 3: Module supply and periphery supply from a common power supply, earthed supply group.

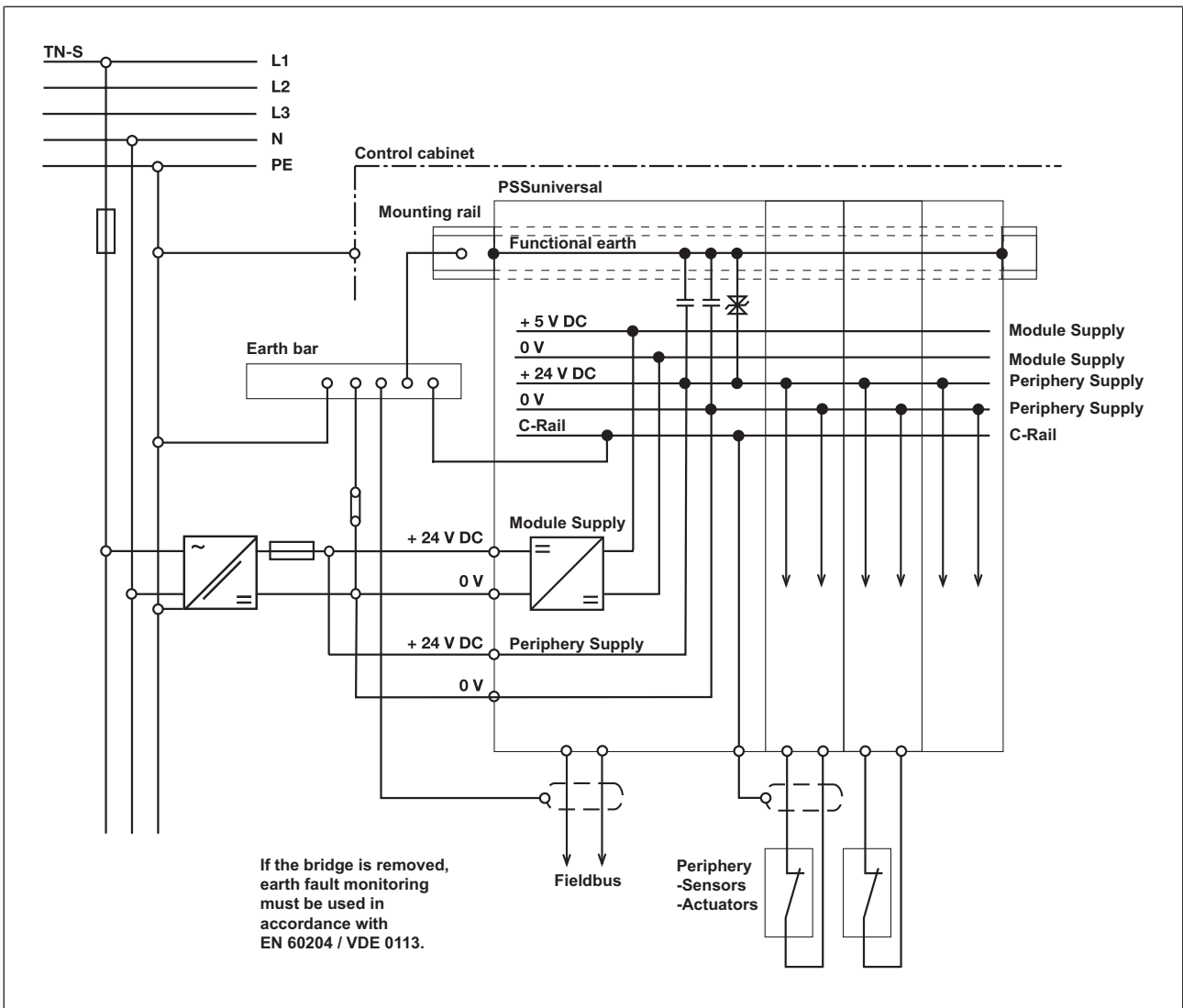

Example 4: Module supply and periphery supply from a common power supply, floating supply group.

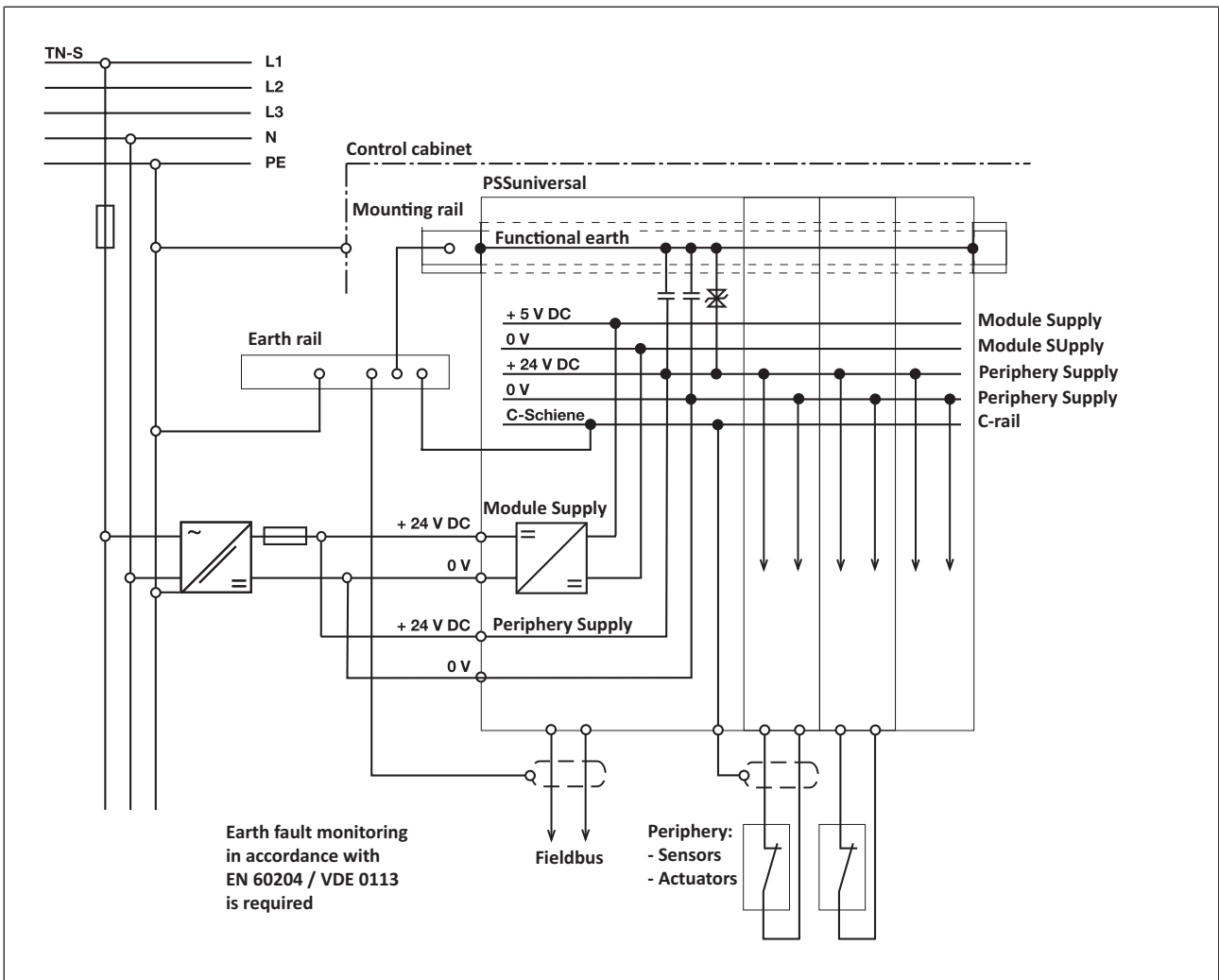

## 6.3 Earthing

When modules are attached to the mounting rail, a contact spring makes the electrical contact between the modules' functional earth and the mounting rail.

- ▶ Always connect the mounting rail to the protective earth via an earthing terminal. This will be used to dissipate hazardous voltages in the case of a fault.

The earthing terminal is available as an accessory. The mounting rail must be properly earthed to ensure interference-free operation in accordance with EMC regulations.

The supplies on the PSSuniversal module bus (module supply, periphery supply, C-rail) are not connected to the functional earth through the contact spring.

On analogue modules and counter modules with base modules without a C-rail, the contact spring also connects the shielding connections to the mounting rail.

Earthing the mounting rail:

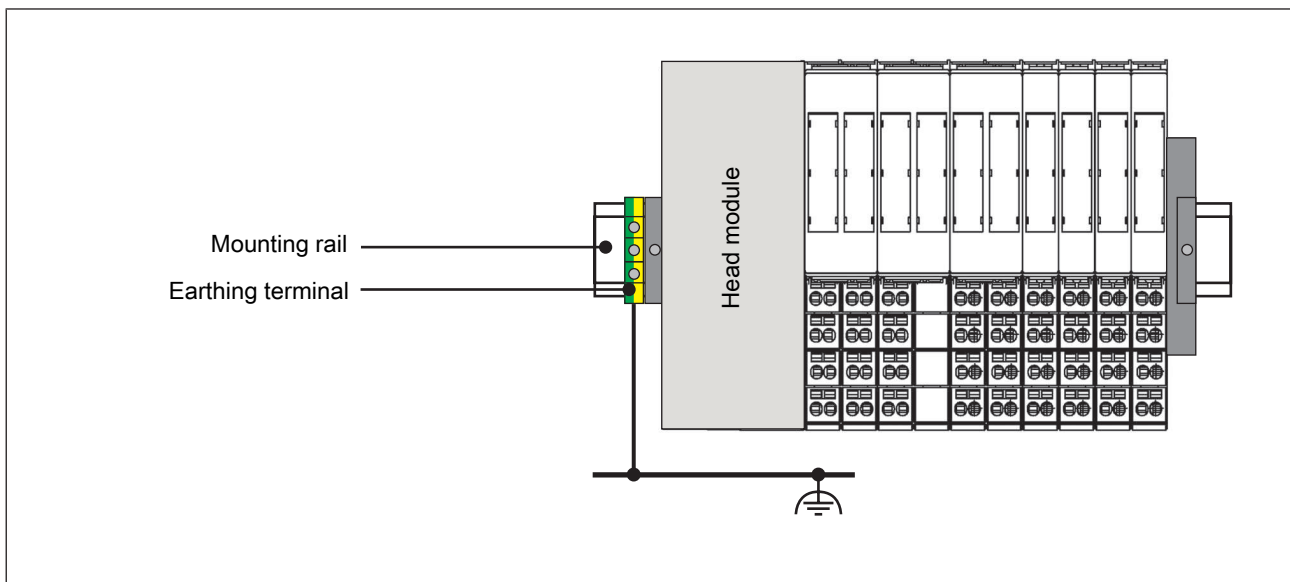

## 6.4 Separation of supply

When used with the relevant base module, any electronic supply voltage module is suitable to separate supplies and form supply groups.

To separate supplies, the supply (periphery supply and C-rail supply) to the preceding (left-hand) modules is disconnected and a new supply provided for subsequent (right-hand) modules.

With a new supply group it is also possible to refresh the module supply by providing a new supply voltage. The 0 V supply on the module supply is never interrupted, but is always looped through across all base modules/compact modules.

You should always refer to the description of the relevant electronic supply voltage module.

The following modules are suitable for separating supplies, for example:

Electronic module	Base module	Module supply	Periphery supply and C-rail
PSSu E F PS	PSSu BS-R 1/8 S PSSu BS-R 1/8 C	Refreshing (new supply voltage is provided, 0 V supply is not interrupted).	Supply of the left-hand modules is interrupted and a new supply is provided for the right-hand modules.
PSSu E F PS1	PSSu BS-R 2/8 S PSSu BS-R 2/8 C		
PSSu E F PS-P	PSSu BS 1/8 S PSSu BS 1/8 C	No refreshing (5 V is not separated).	
PSSu E F BSW	PSSu BS 2/8 S PSSu BS 1/8 C		

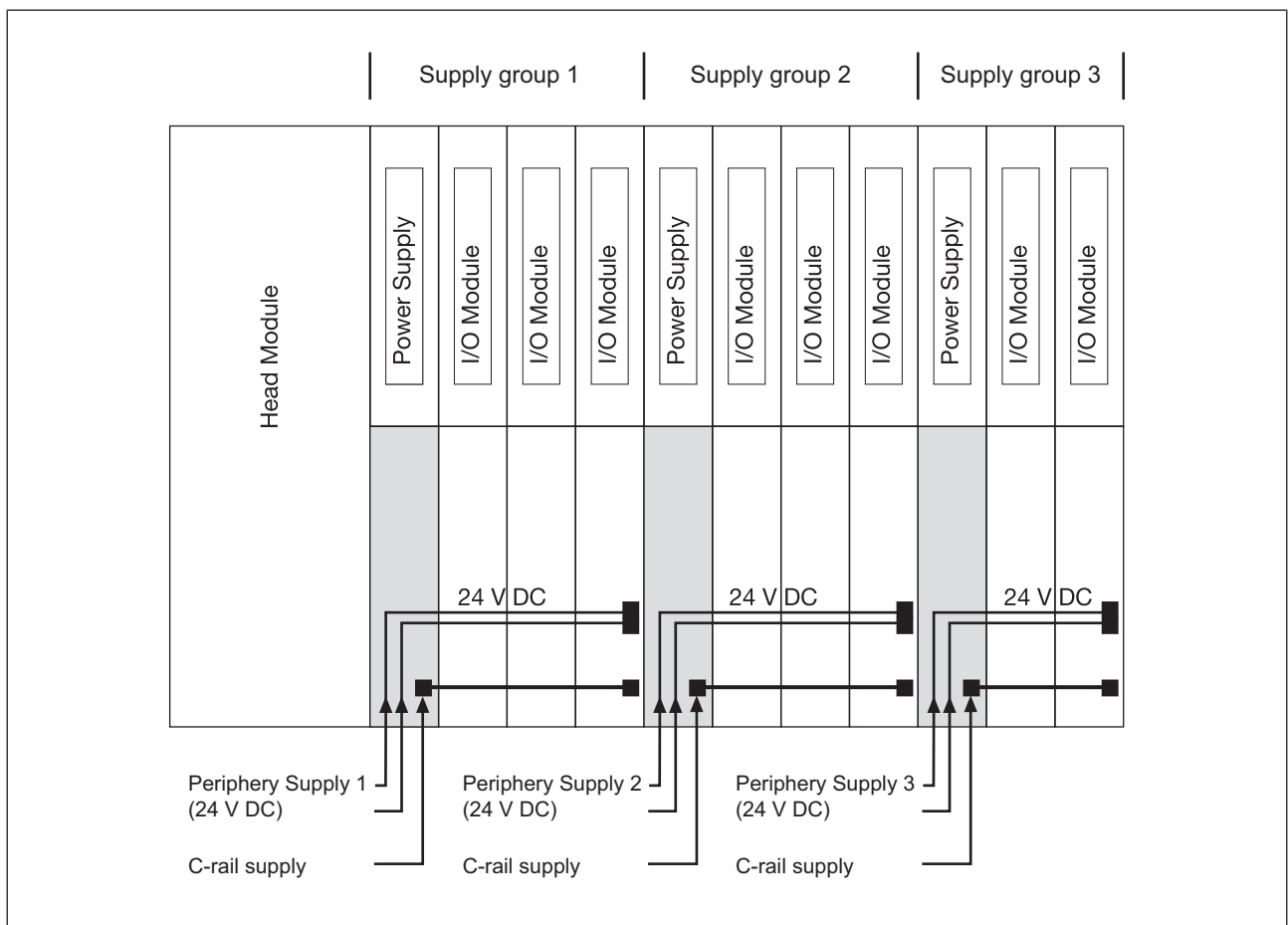

The supply voltage for the first supply group can also be integrated within the head module.

## 6.5 Wiring the base modules

Procedure:

- ▶ Use a flat blade screwdriver (DIN 5264-A)!

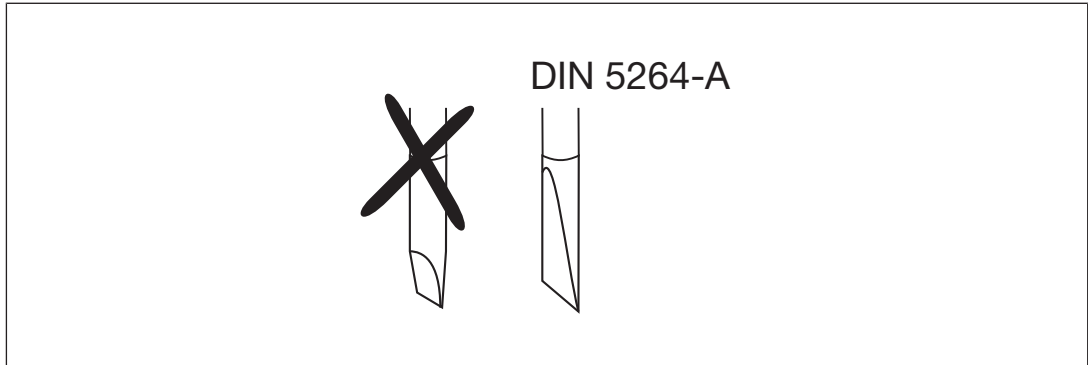

- ▶ Strip the wire back 8 mm.
- ▶ If necessary, label the connection level with a colour marker [3].
- ▶ Base module with screw terminals:
  - Use a screwdriver to loosen the screw on the screw terminal [1]
  - Insert the stripped cable into the round fixing hole [2], as far as it will go.
  - Tighten up the screw on the screw terminal.
  - Check that the cable is firmly seated.
- ▶ Base module with cage clamp terminals:
  - Insert the screwdriver [4] into the square hole [1].
  - Insert the stripped cable into the round fixing hole [2], as far as it will go [5].
  - Pull out the screwdriver [6].
  - Check that the cable is firmly seated.

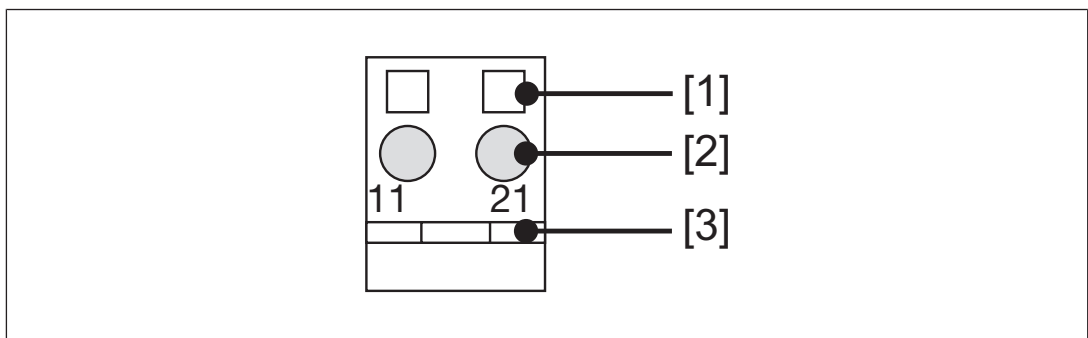

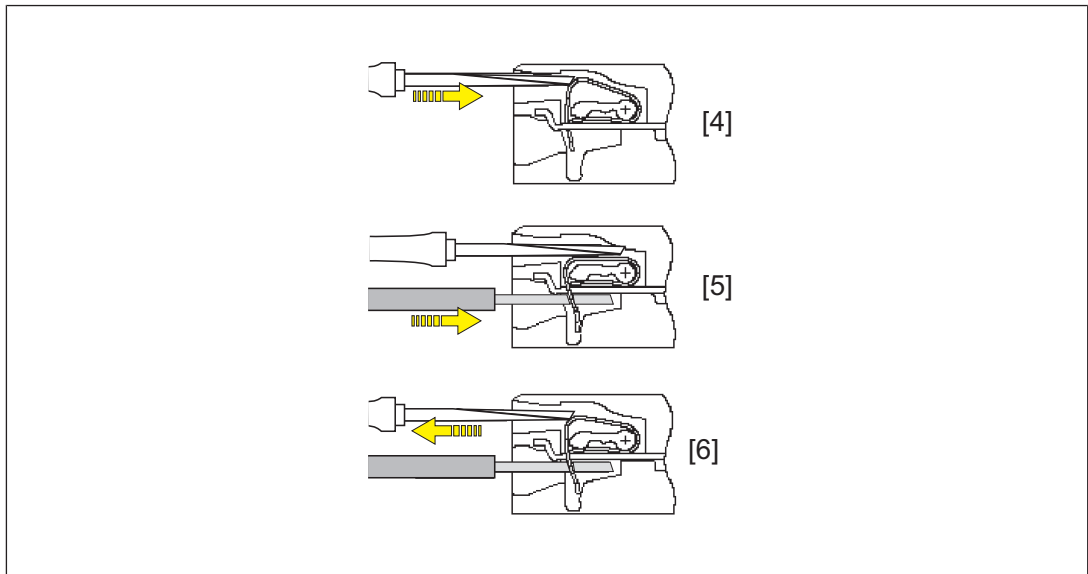

### 6.5.1 Cable requirements

Please note:

- ▶ The minimum cable cross section for field connection terminals on the base modules is 0.14 mm<sup>2</sup> (AWG26).
- ▶ The maximum cable cross section for field connection terminals is:
  - Digital inputs: 1.5 mm<sup>2</sup> (AWG16)
  - Digital outputs: 2.0 mm<sup>2</sup> (AWG14)
  - Inputs/outputs on the counter modules: 1.5 mm<sup>2</sup> (AWG16)
  - Analogue inputs/outputs: 1.5 mm<sup>2</sup> (AWG16)
  - Communication cables: 1.5 mm<sup>2</sup> (AWG16)
  - Test pulse outputs: 1.5 mm<sup>2</sup> (AWG16)
  - Power supply: 2.5 mm<sup>2</sup> (AWG12)
  - Functional earth: 2.5 mm<sup>2</sup> (AWG12)
- ▶ On base modules with screw terminals:
  - If you use a multi-strand cable to connect the I/Os, it is recommended that you use ferrules conforming to Parts 1 and 2 of DIN 46228, 0.14 ... 1.5 mm<sup>2</sup>, Form A or C, although this is not essential. To crimp the ferrules you can use crimp pliers (crimp form A or C) conforming to EN 60947-1, such as the PZ 1.5 or PZ 6.5 from Weidmüller, for example.
  - Maximum torque setting: 0.8 Nm
- ▶ Use copper wiring.

## 6.5.2 Connecting FS inputs and outputs

In FS applications, it is essential that short circuits and open circuits are unable to cause a hazardous condition within a plant.

The way in which this is done will depend on the degree of hazard from the plant section, the switching frequency of the sensors and the level of safety of the sensors and actuators. These points must be assessed in conjunction with the certification body responsible for safety (e.g. BG, TÜV).

Depending on the application area and its respective regulations, the FS section can be used up to SIL CL 3 of EN 62061 and up to PL e (Cat 4) of ISO 13849-1.

Various tests may be configured on FS input/output modules. These tests can be used to detect many short circuits and open circuits. Examples of such tests are:

- ▶ Off tests for outputs that are switched on
- ▶ On tests for outputs that are switched off
- ▶ Tests for shorts between the outputs
- ▶ Test pulses for detecting shorts between contacts on inputs

Wiring guidelines and connection examples are available in the operating manuals or data sheets for the input/output modules.

## 6.6 Wiring the compact modules

We recommend you use a screw driver with a 0.4 x 2.5 mm (DIN 5264) blade!

Strip the cable:

- ▶ Strip the cable [1] and apply a ferrule if necessary (DIN 46228/Part 1 or DIN 46228/Part 4).

Connect cable:

- ▶ Using the screwdriver, press the actuator button on the spring-loaded terminal down as far as it will go [2], keep it held down and insert the stripped cable into the plug connection as far as it will go [2].
- ▶ Check that the cable is firmly seated [3].

Disconnect cable:

- ▶ Using the screwdriver, press the actuator button down as far as it will go [4], keep it held down and pull the cable out of the plug connection [4].

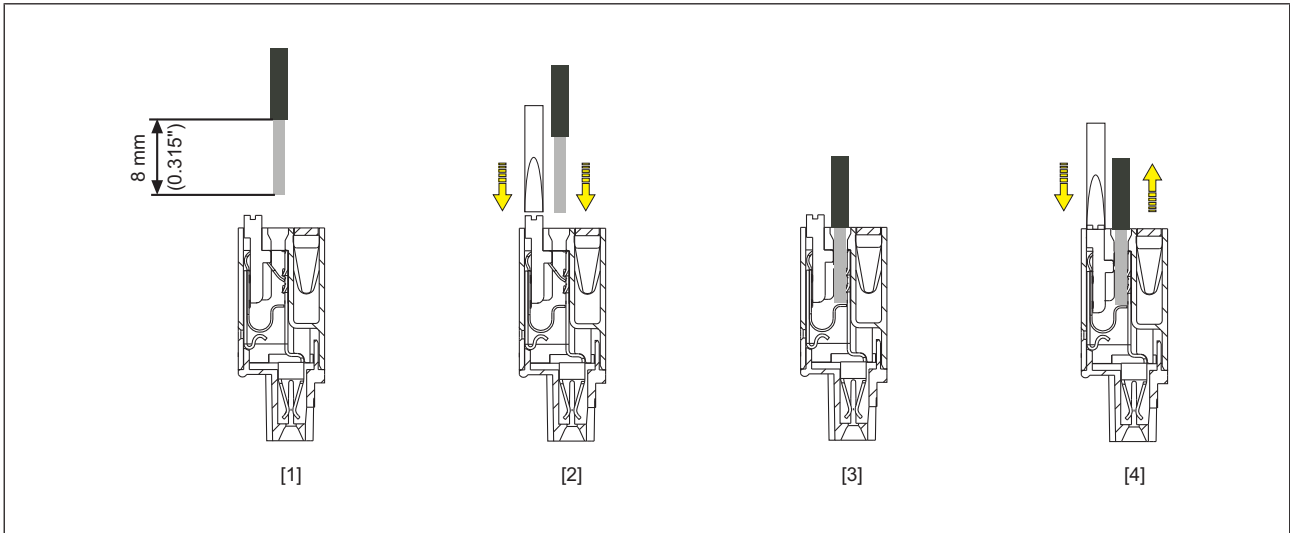

Fig.: Connect and disconnect the cables

### 6.6.1 Cable requirements

Please note:

- ▶ The cable cross section with spring-loaded terminals without ferrules is 0.20 – 1 mm<sup>2</sup>, 22 -16 AWG.
- ▶ If you are using multi-core or fine-core cables we recommend ferrules in accordance with DIN 46228/Part 1 or DIN 46228/Part 4, 0.2 ... 1 mm<sup>2</sup>. To crimp the ferrules we recommend crimping pliers (crimp form A) conforming to EN 60947-1, such as the PZ 6/5 from Weidmüller, for example.
- ▶ Terminal points per connection: 1
- ▶ Stripping length: 8 mm

## 6.7 Wiring test and function test



### CAUTION!

The PSSuniversal may be damaged by wiring errors or by modules being inserted incorrectly.

For this reason, please follow the correct sequence when commissioning.

Prerequisite:

- ▶ Mechanical structure is complete.
- ▶ Wiring is finished.
- ▶ Voltage is not yet applied.

Procedure:

- ▶ Apply the supply voltage for the module supply. Do not apply any other voltages!
- ▶ Download configuration data to the PSSuniversal.
  - The head module checks that the hardware registry is correct. If an electronic module or compact module is inserted incorrectly, this will be detected and will lead to an error message.
- ▶ In the case of an error: Correct the invalid hardware registry.
- ▶ Apply the supply voltage for the periphery supply.
- ▶ Check the functions of the inputs and outputs. Most wiring errors can be detected in this way.
- ▶ In the case of an error: Correct the wiring.
- ▶ If necessary: Apply the C-rail supply.



### WARNING!

Risk of electrocution!

If voltages higher than 50 VAC or 120 VDC are connected to the PSSuniversal, e.g. to switch contacts on relay modules, please note the following:

- Specific accident prevention regulations apply.
- For safety reasons, only the protective earth (PE) may be connected to the C-rail of the supply group.

- ▶ If relay modules with 230 V outputs are used: Connect 230 V.

# Support

Technical support is available from Pilz round the clock.

## Americas

### Brazil

+55 11 97569-2804

### Canada

+1 888 315 7459

### Mexico

+52 55 5572 1300

### USA (toll-free)

+1 877-PILZUSA (745-9872)

## Asia

### China

+86 400-088-3566

### Japan

+81 45 471-2281

### South Korea

+82 31 778 3300

## Australia and Oceania

### Australia

+61 3 95600621

### New Zealand

+64 9 6345350

## Europe

### Austria

+43 1 7986263-444

### Belgium, Luxembourg

+32 9 3217570

### France

+33 3 88104003

### Germany

+49 711 3409-444

### Ireland

+353 21 4804983

### Italy, Malta

+39 0362 1826711

## Scandinavia

+45 74436332

## Spain

+34 938497433

## Switzerland

+41 62 88979-32

## The Netherlands

+31 347 320477

## Turkey

+90 216 5775552

## United Kingdom

+44 1536 462203

## You can reach our international hotline on:

+49 711 3409-222

support@pilz.com

Pilz develops environmentally-friendly products using ecological materials and energy-saving technologies. Offices and production facilities are ecologically designed, environmentally-aware and energy-saving. So Pilz offers sustainability, plus the security of using energy-efficient products and environmentally-friendly solutions.



We are represented internationally. Please refer to our homepage [www.pilz.com](http://www.pilz.com) for further details or contact our headquarters.

Headquarters: Pilz GmbH & Co. KG, Felix-Wankel-Straße 2, 73760 Ostfildern, Germany  
Telephone: +49 711 3409-0, E-Mail: [info@pilz.com](mailto:info@pilz.com), Internet: [www.pilz.com](http://www.pilz.com)

**PILZ**  
THE SPIRIT OF SAFETY

CECE<sup>®</sup>, CHRE<sup>®</sup>, CMSE<sup>®</sup>, INDUSTRIAL P<sup>®</sup>, Leansafe<sup>®</sup>, Myzel<sup>®</sup>, PAS4000<sup>®</sup>, PASscal<sup>®</sup>, PASconfig<sup>®</sup>, Pilz<sup>®</sup>, PIT<sup>®</sup>, PMSprimo<sup>®</sup>, PMSprotego<sup>®</sup>, PMCiendo<sup>®</sup>, PMD<sup>®</sup>, PME<sup>®</sup>, PNOZ<sup>®</sup>, Primo<sup>®</sup>, PSEN<sup>®</sup>, PSS<sup>®</sup>, PSS<sup>®</sup>, PVIS<sup>®</sup>, SafetyBUS p<sup>®</sup>, SafetyNET p<sup>®</sup>, THE SPIRIT OF SAFETY<sup>®</sup> are registered and protected trademarks of Pilz GmbH & Co. KG in some countries. We would point out that product features may vary from the details stated in this document, depending on the status at the time of publication and the scope of the equipment. We accept no responsibility for the validity, accuracy and entirety of the text and graphics presented in this information. Please contact our Technical Support if you have any questions.

21262-EN-09, 2023-09 Printed in Germany  
© Pilz GmbH & Co. KG, 2019